



GEMINI™

810 + 980 DIODE LASER

USER MANUAL

Meticulous
Structured

CREATIVE

INCREDIBLY

Innovative

TECHNOLOGY

GEMINI[™]
810 + 980 DIODE LASER

Rx

FEDERAL LAW RESTRICTS THIS DEVICE TO
SALE BY OR ON THE ORDER OF A DENTIST
OR PHYSICIAN OR OTHER LICENSED MEDICAL
PRACTITIONER

Laser technology enables clinicians to provide less invasive treatment for many preventative, restorative, cosmetic, and surgical soft tissue procedures. The Gemini 810 + 980 diode laser represents a new advancement in dental laser technology. With its unique eye-catching design, simple user interface, and multiple wavelength modes, you can perform a range of soft-tissue procedures with ease.

The Gemini 810 + 980 diode laser is the first soft tissue dental laser to provide a choice of two laser wavelengths in one system. You have the ability to select laser settings that best suit specific procedures and patient needs based on tissue type and optimal wavelength absorption characteristics.

Inspiration

The true sign of intelligence is not knowledge but imagination.

Albert Einstein

You will discover that the Gemini 810 + 980 diode laser cuts faster, reduces tissue tagging and generates less collateral thermal heat than other diode lasers you may have used, allowing you to provide a higher standard of care. The laser also features an incredible, innovative transparent display designed to wow your patients.

Choosing to integrate laser technology into your practice yields many benefits, including increased patient comfort and satisfaction and more efficient treatment. To get the maximum benefits of laser technology, consider joining a study group so that you can exchange tips and ideas with fellow clinicians. A study group is also an excellent way to keep abreast of the latest procedures and technological advances. A great place to start is the Academy of Laser Dentistry, www.laserdentistry.org.

WARNINGS & CAUTIONS

Failure to comply with precautions and warnings described in this User Manual may lead to exposure to dangerous optical radiation sources. Please comply with all safety instructions and warnings.



CAUTION: Read these instructions carefully prior to using your Gemini 810 + 980 diode laser.



CAUTION: Ensure that all users are properly trained prior to use. Consult your distributor for training recommendations.



CAUTION: Do not modify this equipment without authorization of the manufacturer.



CAUTION: Always wind the fiber optic cable in a clockwise manner around the fiber wrap to avoid fiber breakage (See Page 26).



CAUTION: Do not use in the presence of combustible or combustion-supporting gases.
CAUTION: Always test activate the device outside the mouth before using on a patient.



CAUTION: This unit has been designed and tested to meet the requirements of electromagnetic, electrostatic, and radio frequency interference standards. However, the possibility of electromagnetic or other interference may still exist. Relocating the device may help to eliminate the interference.



CAUTION: Medical electrical equipment needs special precautions regarding electromagnetic compatibility (EMC) and needs to be installed and put into service according to the EMC information provided in pages 44-48 of this manual.



CAUTION: Periodically inspect laser eyewear for pitting and cracking.

Safety is paramount when using any energy-based surgical instrument, and your office should implement a safety program for the Gemini 810 + 980 diode laser. If your office does not already have a safety officer, one should be appointed to be responsible for understanding proper use, safe operation, and maintenance of the Gemini laser system. Their duties should include training office personnel in all aspects of system safety and management of the Gemini laser and all accessories.

WARNINGS & CAUTIONS



WARNING: Visible and Invisible Laser Radiation – Avoid eye or skin exposure to direct or scattered radiation.

Class IV Laser Product



WARNING: Laser Safety Eye Protection **MUST BE WORN** by the Operator, Patient, Assistant, and anyone present when the laser is activated. Eye Protection must conform to Specification DIN EN207 Annex II of the Directive 89/686/EEC with wavelength protection of 810 nm-980 nm, and ± 10 nm of OD 5+ such as NoIR Laser Company filter model CYN.



WARNING: Never direct or point the beam at a person's eyes.



WARNING: Do not look directly into the beam or at specular reflections.



WARNING: Do not aim the laser at metallic or reflective surfaces, such as surgical instruments or dental mirrors. If aimed directly at these surfaces the laser beam will reflect and create a potential hazard.



WARNING: Never operate the laser without a fiber tip attached.



WARNING: Laser aperture at the end of the handpiece.

WARNING: Laser aperture warning label affixed to system handpiece.



WARNING: Always place the system into **STANDBY** mode when leaving the Gemini 810 + 980 diode laser unattended for few minutes or between patients.



WARNING: Use of controls or adjustments or performance of procedures other than those specified herein may result in hazardous radiation exposure.



WARNING: Do not open unit housing at any time. Danger from optical radiation may exist.



WARNING: The use of accessories, other than those specified, except those supplied or sold by Ultradent Products, Inc., as replacement parts for internal or external components, may result in increased **EMMISSIONS** or decreased **IMMUNITY** of the Gemini 810 + 980 diode laser. Refer to pages 44-48 for additional information.

WHAT IS IN THE BOX

Purchase of the Gemini 810 + 980 diode laser includes the following.

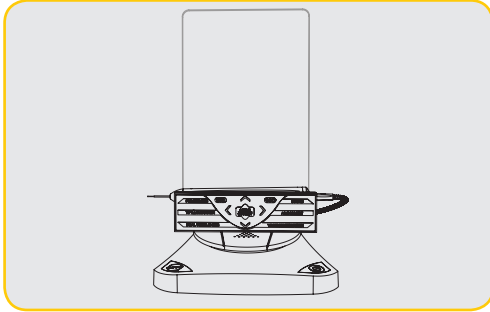

Laser Unit

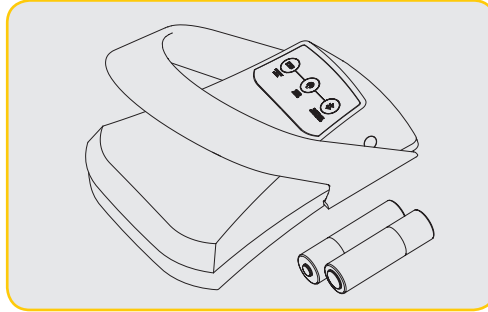

Activation Pedal with 2 AA Batteries

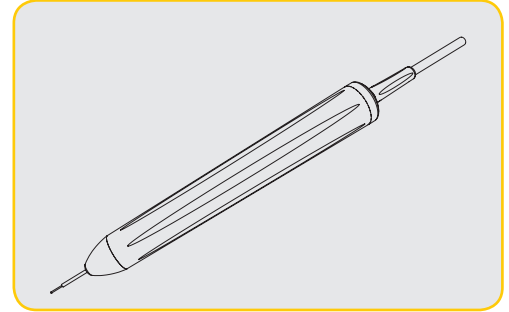

Fiber Delivery System

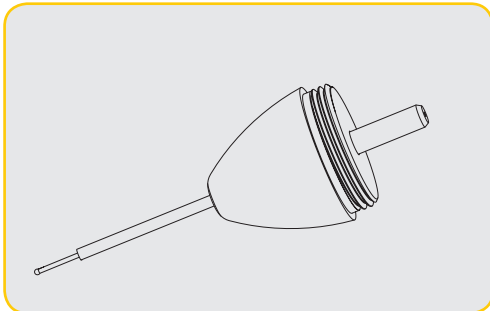

Disposable Tips (10)

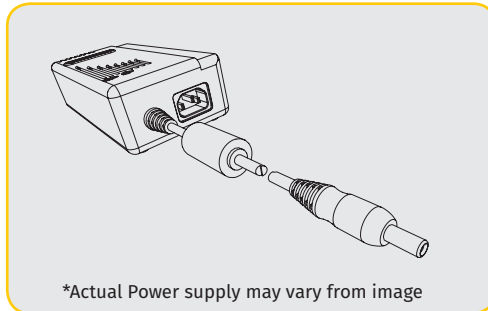

*Actual Power supply may vary from image

*DC Power Supply

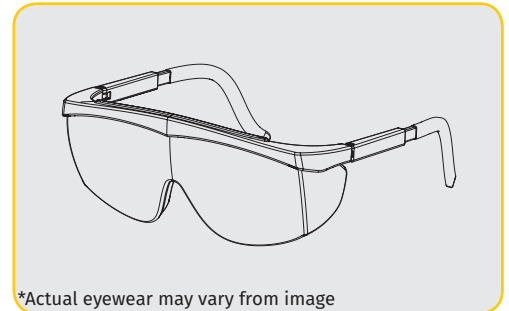

*Actual eyewear may vary from image

*Protective Eyewear (3)

- Laser Warning Sign
- Warranty Information
- USB Cable
- User Manual

NOTE: The laser ships with the lithium ion battery and fiber delivery system already installed

NOTE: Use proper care when transporting the unit

WARNING: No modification of this equipment is allowed

UNPACKING INSTRUCTIONS

A manufacturer or dealer representative can provide assistance when you are ready to remove the Laser from its shipping container. Please do not attempt to unpack the Gemini 810 + 980 diode laser and install the system without reading this manual first. If you are unsure about any aspect of the assembly, call your customer service representative or dealer for assistance.

SHIPPING CONTAINER INFORMATION

The shipping container you received with your Gemini 810 + 980 diode laser was specially designed to safely transport the device. In the unlikely event that you need to return the laser for service or repair, please retain the original shipping container.

TABLE OF CONTENTS

Overview

Display	08
Keypad	09
Laser Unit	10
Activation Pedal	11
Fiber Delivery System	12
Quick Start	13

Controls - Operation & Use

01 - Electronic Key Passcode	14
02 - Selecting a Wavelength	15
03 - Activation Pedal Connection	16
04 - Manual Power Adjustment	17
05 - Laser Standby and Active Modes	18
06 - 08 - Preset Procedures Settings	19-21
09 - Disposable Tip Operation	22
10 - Initiation of Fiber Tips	23
11 - Tip Illumination	23
12 - Sound	24
13 - Aiming Light	24
14 - Battery and Battery Level Indications	25
15 - Power Supply	25
16 - Fiber Wrapping	26
17 - Hand Piece Magnet	27
18 - Operating Mode	27
19 - Emergency Stop	28
20 - Remote Interlock	28
21 - Transparent Electroluminescent Display	29

Cleaning and Sterilization Procedures	30
---	----

Procedural Recommendations	32
----------------------------------	----

Facility & Environmental Considerations.....	33
--	----

General Safety Considerations.....	34-37
------------------------------------	-------

System Specifications.....	38
----------------------------	----

Service and Troubleshooting.....	39-42
----------------------------------	-------

Regulatory Compliance	43
-----------------------------	----

Electromagnetic Environment Guidance	44-48
--	-------

Labeling	49-52
----------------	-------

OVERVIEW - DISPLAY

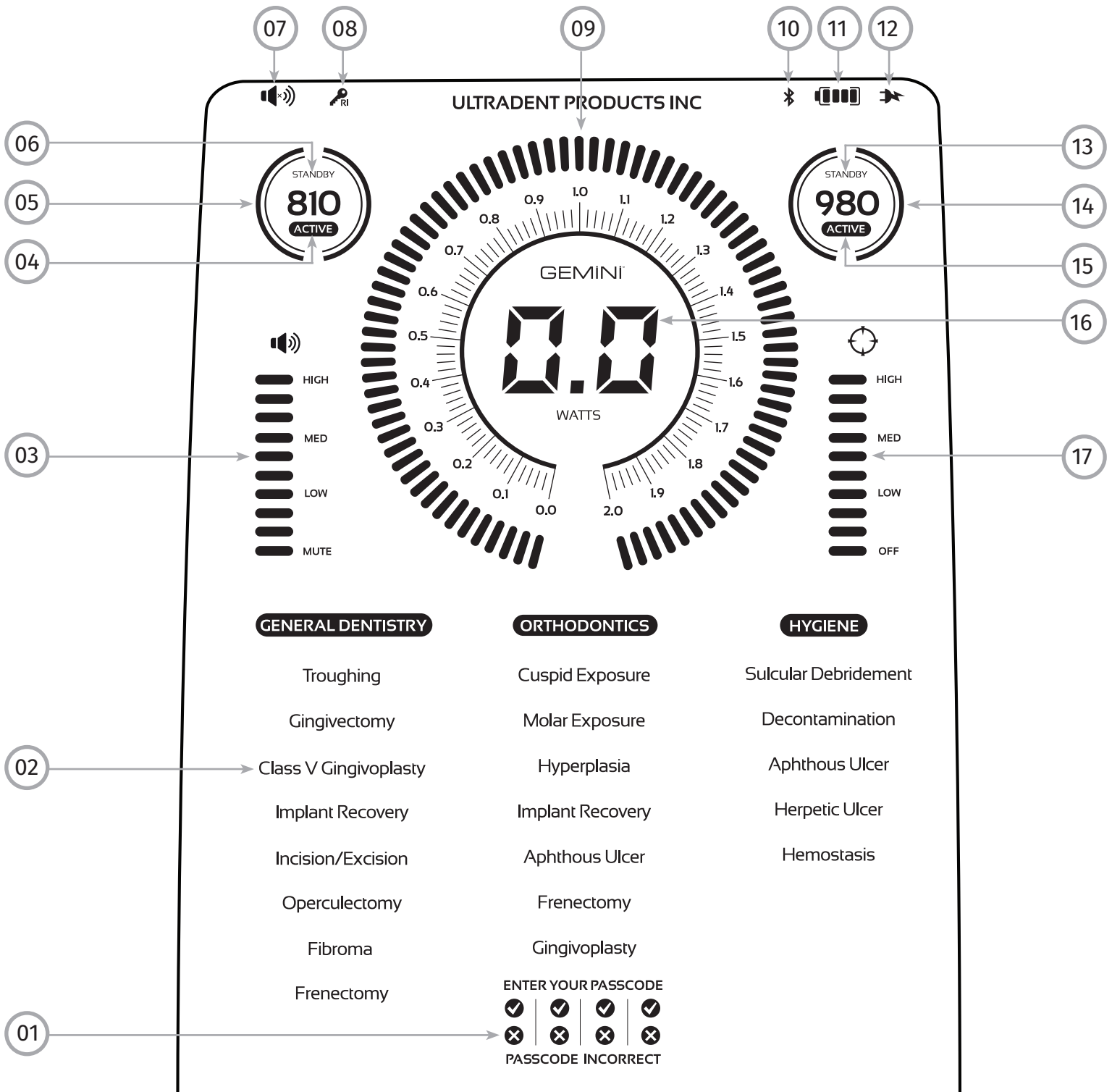

- | | | |
|--------------------------|------------------------|-----------------------|
| 01 - ELECTRONIC PASSCODE | 07 - VOLUME INDICATION | 13 - 980 STANDBY MODE |
| 02 - PRESET PROCEDURES | 08 - REMOTE INTERLOCK | 14 - 980 WAVELENGTH |
| 03 - SOUND LEVEL | 09 - POWER DIAL | 15 - 980 ACTIVE MODE |
| 04 - 810 ACTIVE MODE | 10 - BLUETOOTH | 16 - POWER INDICATION |
| 05 - 810 WAVELENGTH | 11 - BATTERY LEVEL | 17 - AIMING LIGHT |
| 06 - 810 STANDBY MODE | 12 - POWER ADAPTER | |

OVERVIEW - KEYPAD

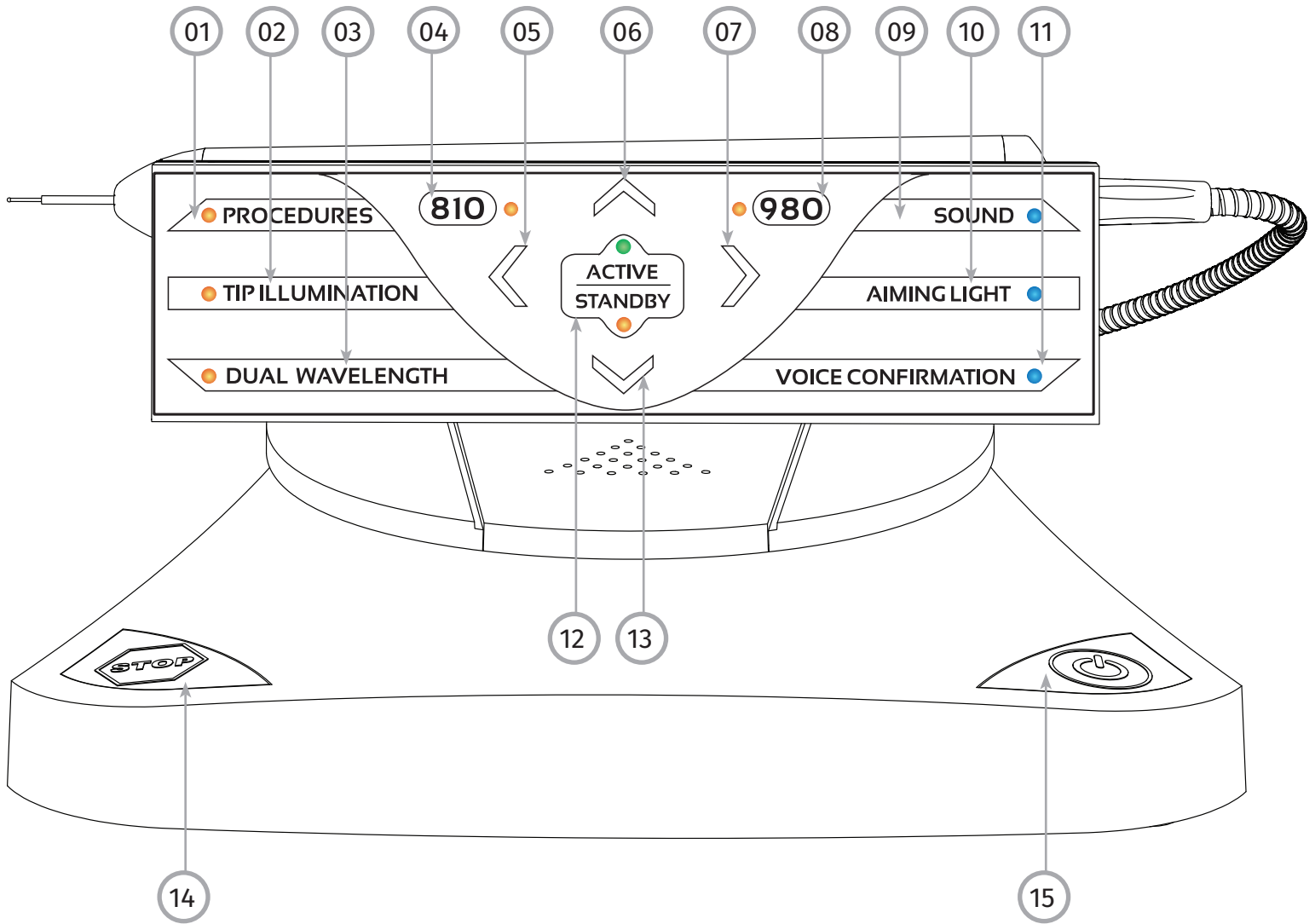

01 - PRESET PROCEDURES	07 - RIGHT ARROW	13 - DOWN ARROW
02 - TIP ILLUMINATION	08 - 980 WAVELENGTH	14 - EMERGENCY STOP
03 - DUAL WAVELENGTH	09 - SOUND	15 - ON/OFF
04 - 810 WAVELENGTH	10 - AIMING LIGHT	
05 - LEFT ARROW	11 - VOICE CONFIRMATION	
06 - UP ARROW	12 - ACTIVE/STANDBY	

OVERVIEW - LASER UNIT

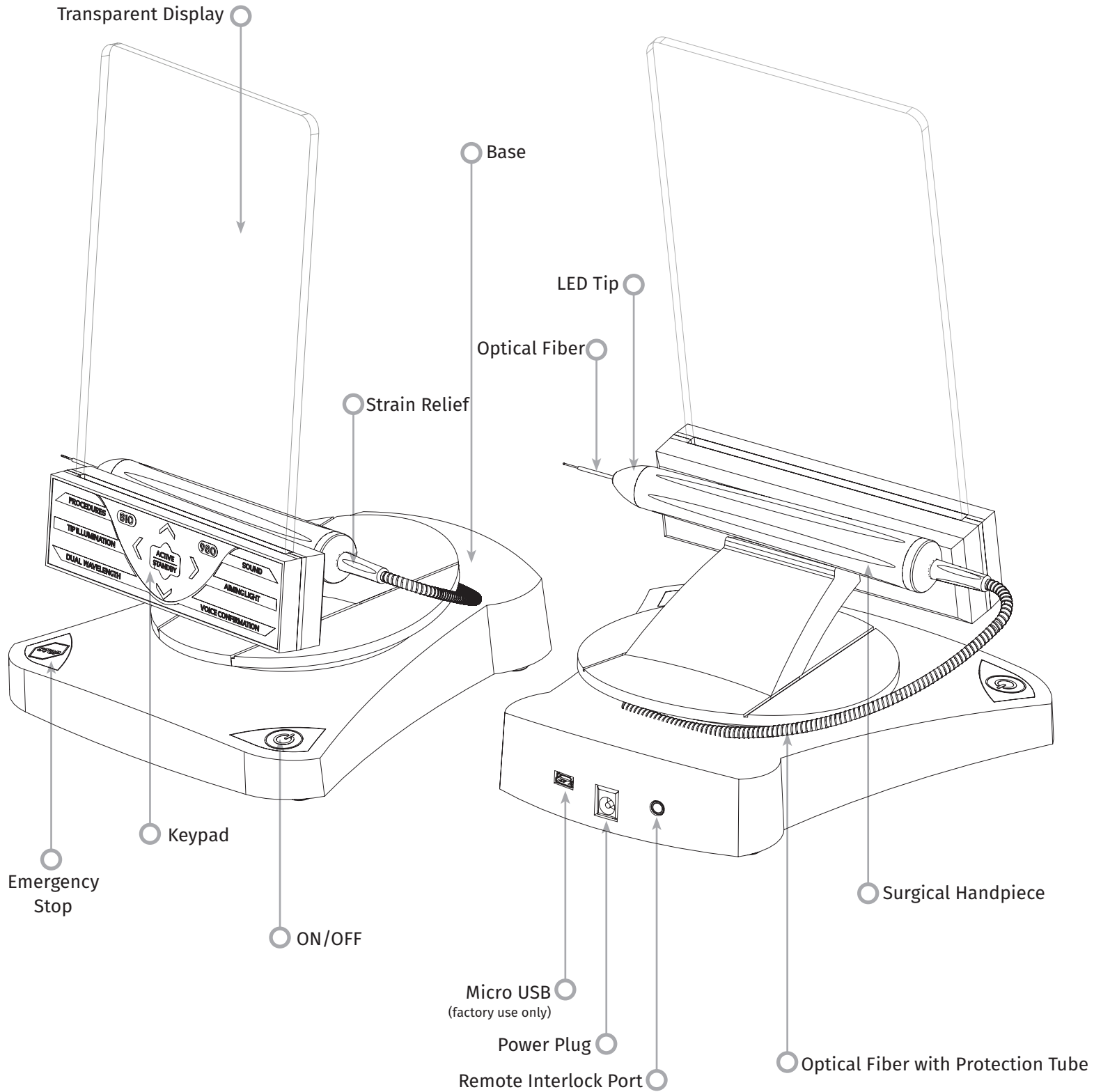

OVERVIEW - ACTIVATION PEDAL

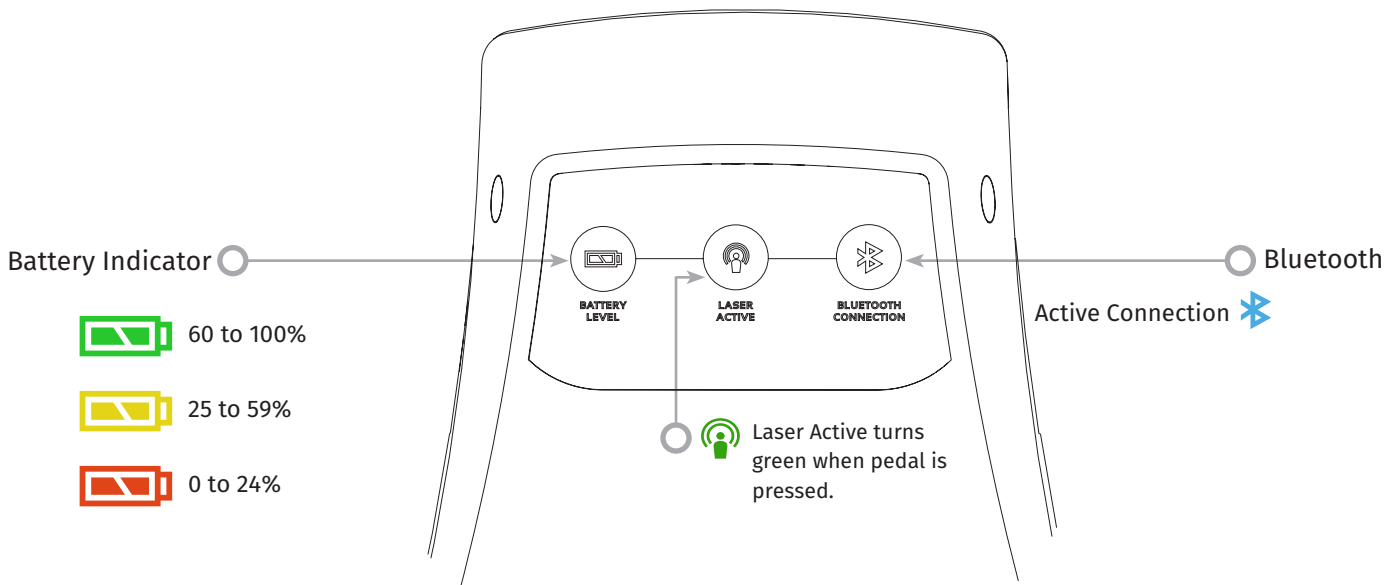
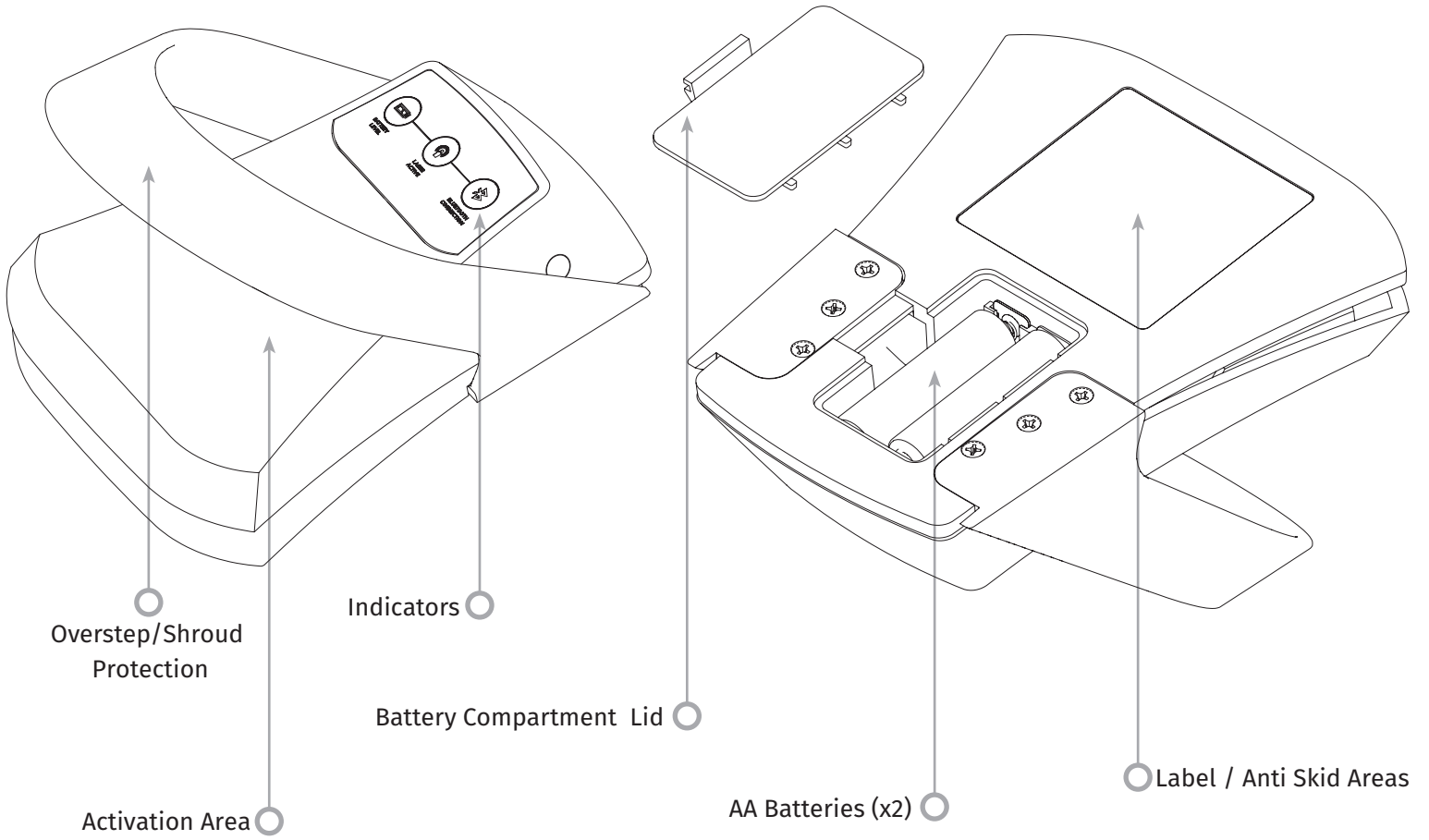

OVERVIEW - FIBER DELIVERY SYSTEM

The fiber delivery system is a unique and ergonomic optical cable that is non-detachable from the laser unit. The handpiece will require cleaning and sterilization after each patient treatment. Disposable tips are intended for single-use only and must be disposed of after each patient use.

Refer to page 30 for cleaning and sterilization procedures.

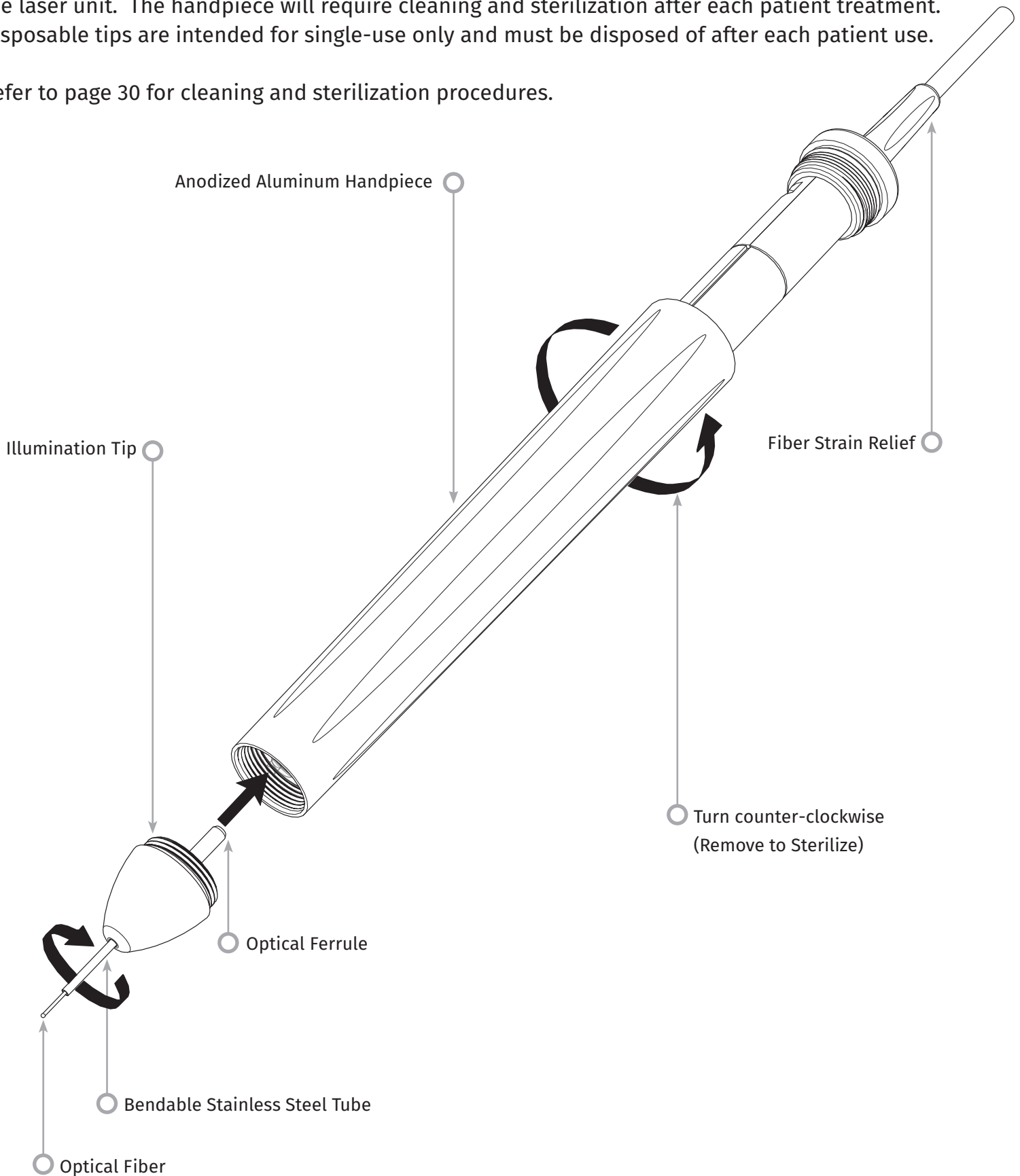

QUICK START

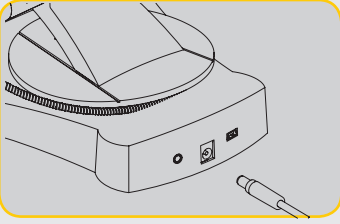

1. Plug In Power Supply

During initial setup use the AC/DC power supply for at least one hour to fully charge the battery. Plug the power supply into an AC outlet and connect to the corresponding connector on the rear of the system.

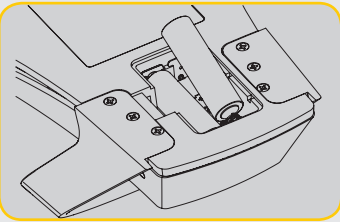

2. Insert AA Batteries into Activation Pedal

Install the (2) provided AA batteries into the wireless activation pedal. When replacing the AA batteries, we recommend an ALKALINE type battery.

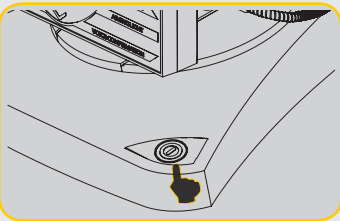

3. Turn Laser Unit ON

The universal ON/OFF button is a membrane switch that requires pressure in order to be activated.

ENTER YOUR PASSCODE



4. Enter Electronic Key Passcode

Enter the electronic key passcode on the keypad using the UP and DOWN arrow keys. The security code is **UP, DOWN, UP, DOWN**. A checkmark icon will appear when the correct key is input.

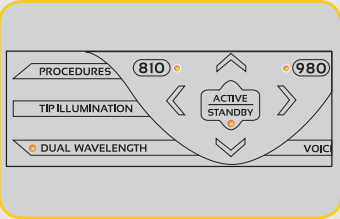

5. Select Your Desired Wavelength

Select the desired laser wavelength on the keypad:
810 nm, 980 nm, or Dual Wavelength.

“Please select wavelength”



6. Select Your Desired Power Setting

Select your desired power setting, then activate the laser. (Pages 17-21)

CONTROLS, OPERATION & USE

01 - ELECTRONIC KEY PASSCODE

The Gemini 810 + 980 diode laser is equipped with an electronic key passcode. When you turn the laser unit on, the passcode key screen will be displayed at the bottom center of the screen. The correct passcode sequence should be entered on the Keypad:

UP, DOWN, UP, DOWN

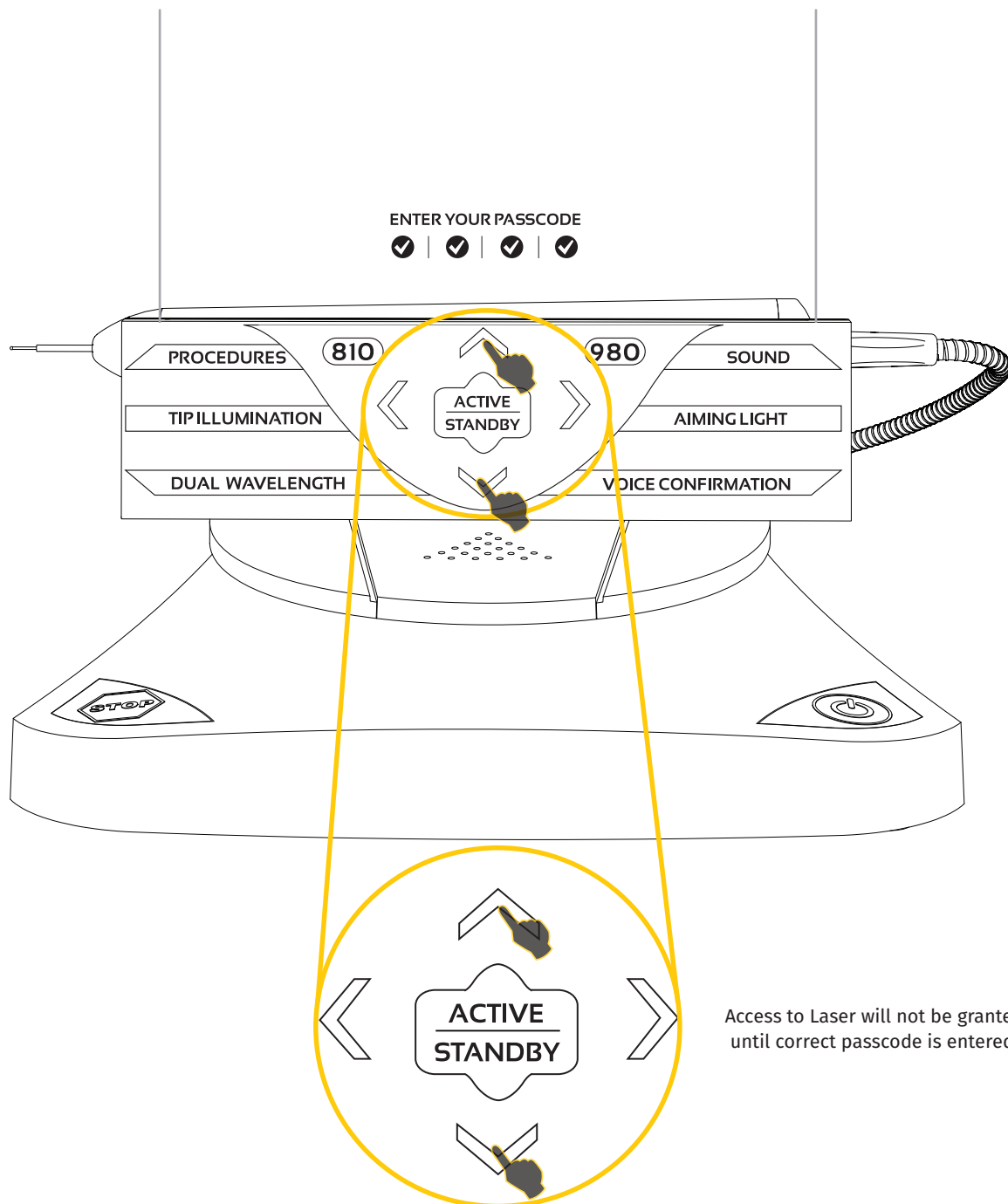

CONTROLS, OPERATION & USE

02 - SELECTING A WAVELENGTH

When the system is turned on, and the electronic passcode is properly input (Page 14), you will be prompted to select the desired wavelength. A voice confirmation will say, "Please select wavelength," and two wavelength rings will flash. The Gemini 810 + 980 diode laser can operate in three wavelength modes: 810 nm alone, 980 nm alone, or Dual Wavelength. A wavelength mode must be selected before proceeding further, but may be changed at any time.

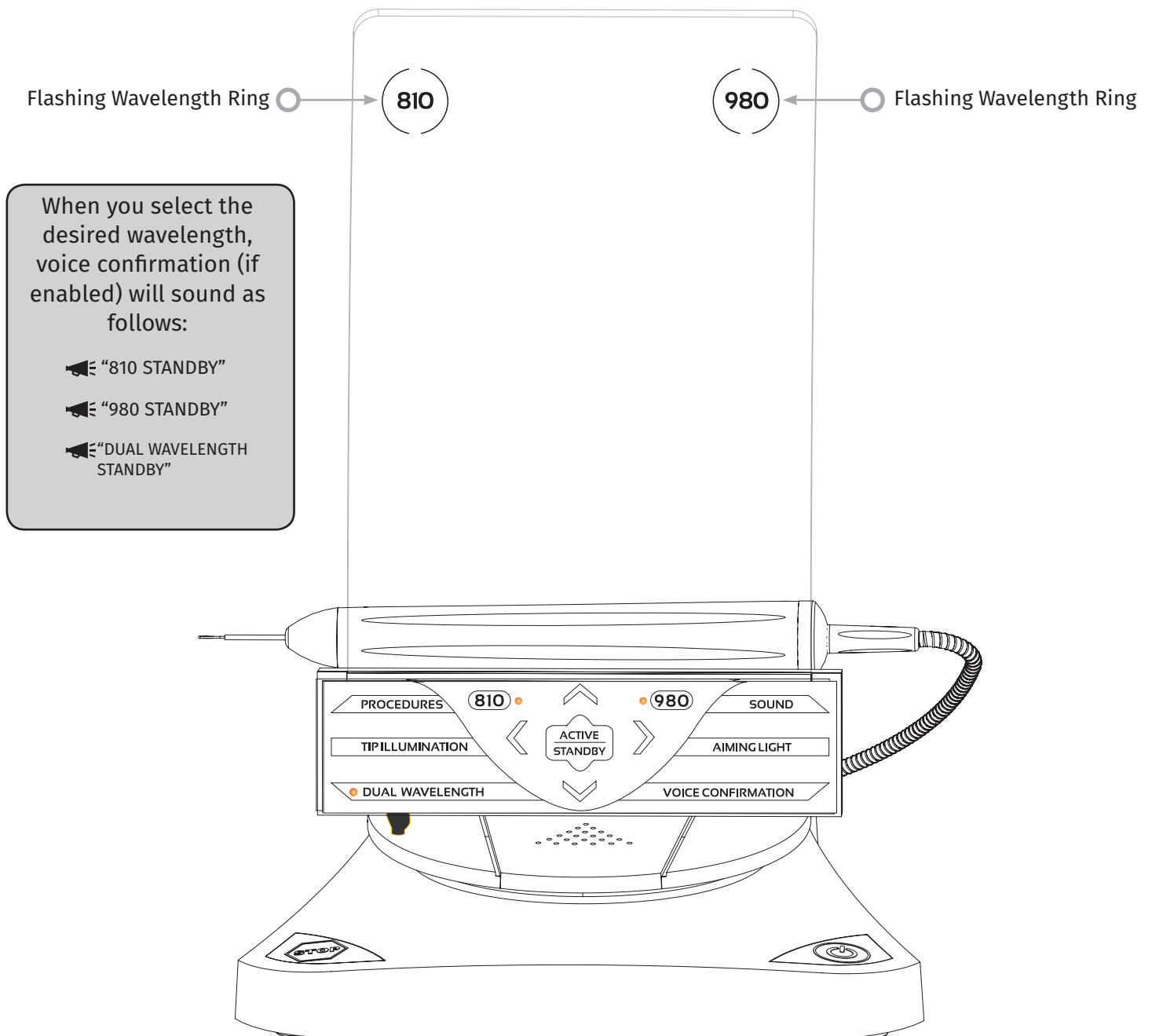

CONTROLS, OPERATION & USE

03 - ACTIVATION PEDAL CONNECTION

Connecting the activation pedal to your laser unit via Bluetooth for the first time is simple.

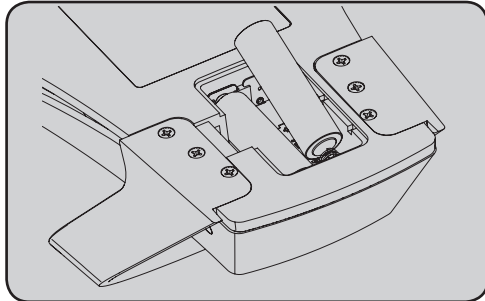

Install the provided 2 AA batteries into the Activation Pedal.

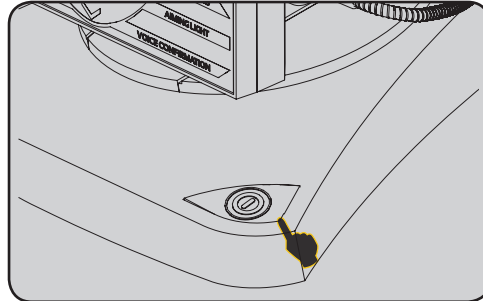

Turn the laser unit ON.



Enter the passcode.

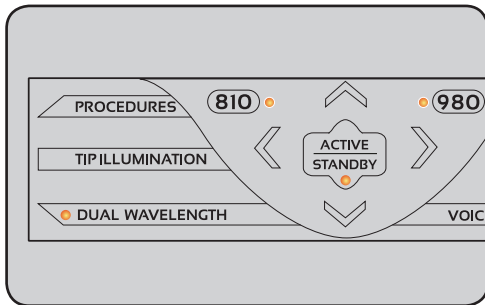

Select the wavelength of choice.

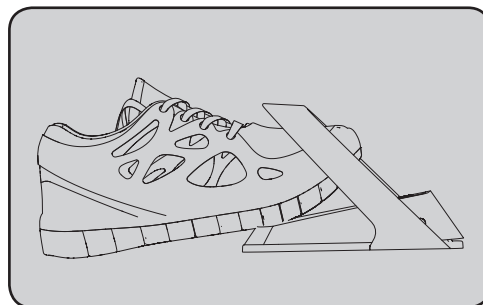

Depress the activation pedal. Connection between the activation pedal and laser unit is done automatically.

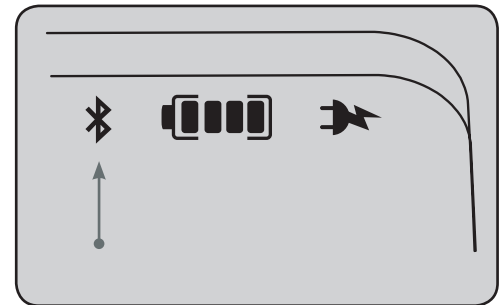

A Bluetooth indicator will appear on the display and activation pedal when it is properly connected and the laser is in Active mode.

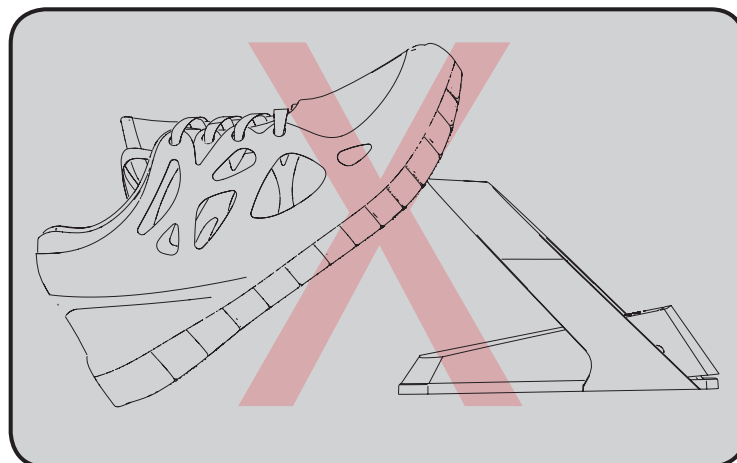

The activation pedal comes with a protective shroud to prevent accidental laser activation. Please do not step on the protective shroud as it could result in accidental damage to the activation pedal.

CONTROLS, OPERATION & USE

04 - MANUAL POWER ADJUSTMENT

The Gemini 810 + 980 diode laser can output up to a maximum of 2.0 watts of average power. To adjust the power setting manually, touch the UP and DOWN or the LEFT and RIGHT arrows on the keypad. Each touch of an arrow raises or lowers the power by 0.1 watts. Touching and holding an arrow will increase the speed in which the power setting is raised or lowered. Touch the ACTIVE button to put the laser in active mode. Depress the activation pedal to activate the laser.

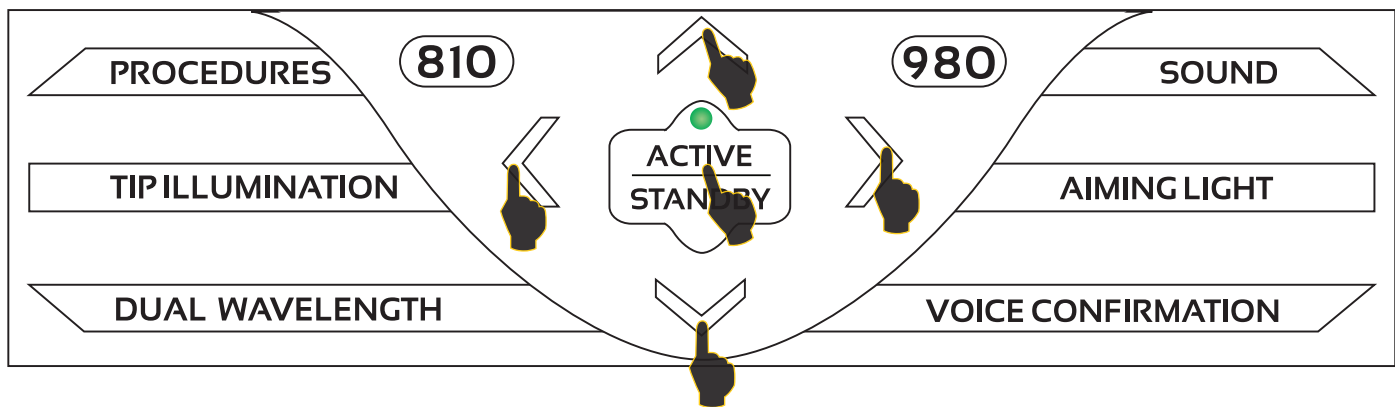
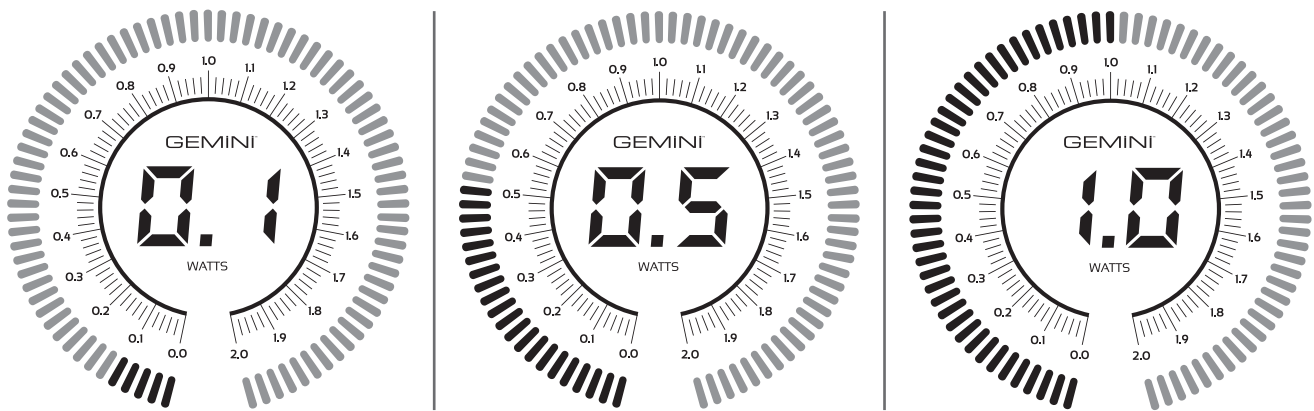

CLINICAL TIP

Maximum results will be achieved by regulating the power output of the laser and the speed at which the operator moves the fiber optic tip. Tissue charring is an undesirable aftereffect of using too much power or of the fiber tip moving too slowly. Always use the least amount of power that is required to complete your procedure. The ideal treatment will result in little or no discoloration, less collateral damage, and faster healing.

Avoid penetrating or damaging the periosteum, and do not attempt to use the laser on alveolar bone. Because the laser energy is attracted to melanin and hemoglobin, power must be reduced when treating patients with dark-pigmented soft tissue.

CONTROLS, OPERATION & USE

05 - LASER STANDBY AND ACTIVE MODES

The ACTIVE/STANDBY keypad selection serves a dual purpose. It activates (ACTIVE) and deactivates the laser (STANDBY). By default, the system powers up in Standby mode. The laser cannot be activated prior to selecting a wavelength. Each time the ACTIVE/STANDBY selection is touched, the system toggles between Active and Standby modes. There is an audio confirmation (unless voice confirmation is muted), and an icon for either “ACTIVE” or “STANDBY” is displayed near each wavelength indicator. The red aiming beam and tip illumination are visible only when the laser is in Active mode.

When the system is in Active mode, touching any selection other than UP and DOWN or LEFT and RIGHT will return the system to the Standby mode. When the activation pedal is depressed in the Active mode, the outer indicator ring around each wavelength icon on the display flashes to provide a visual indication that the laser is firing. There is also an audio beep when laser is being fired. For safety purposes, a laser firing delay of 0.25 seconds was implemented in order to prevent accidental activation.

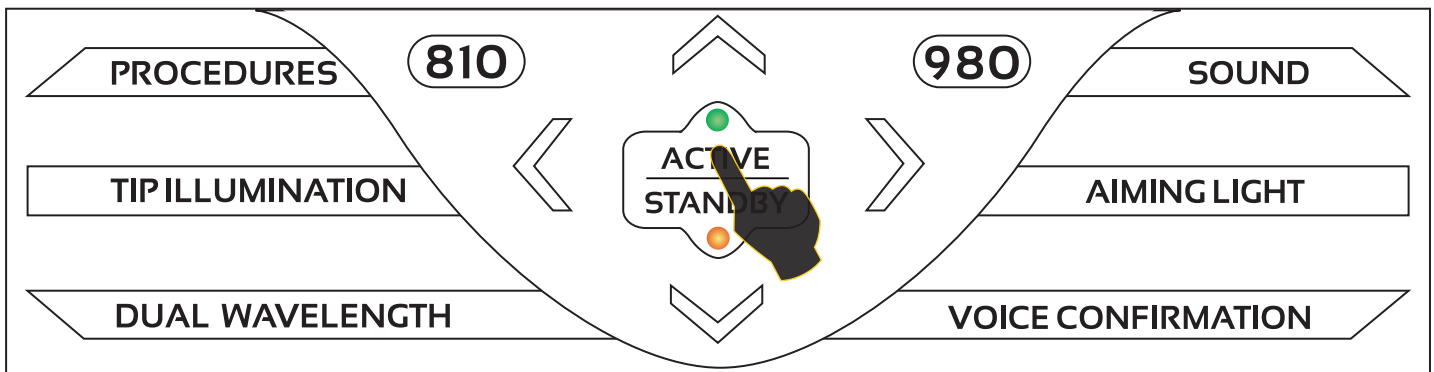

CONTROLS, OPERATION & USE

06 - PRESET PROCEDURE SETTINGS

Touch the PROCEDURES selection to bring up all the preset procedures on the display. Selecting the LEFT and RIGHT arrows will toggle between GENERAL DENTISTRY, ORTHODONTICS or HYGIENE categories. Selecting the UP and DOWN arrows will toggle between procedures within each category. The corresponding power setting for each procedure is displayed on the Power Indicator when the procedure is highlighted.

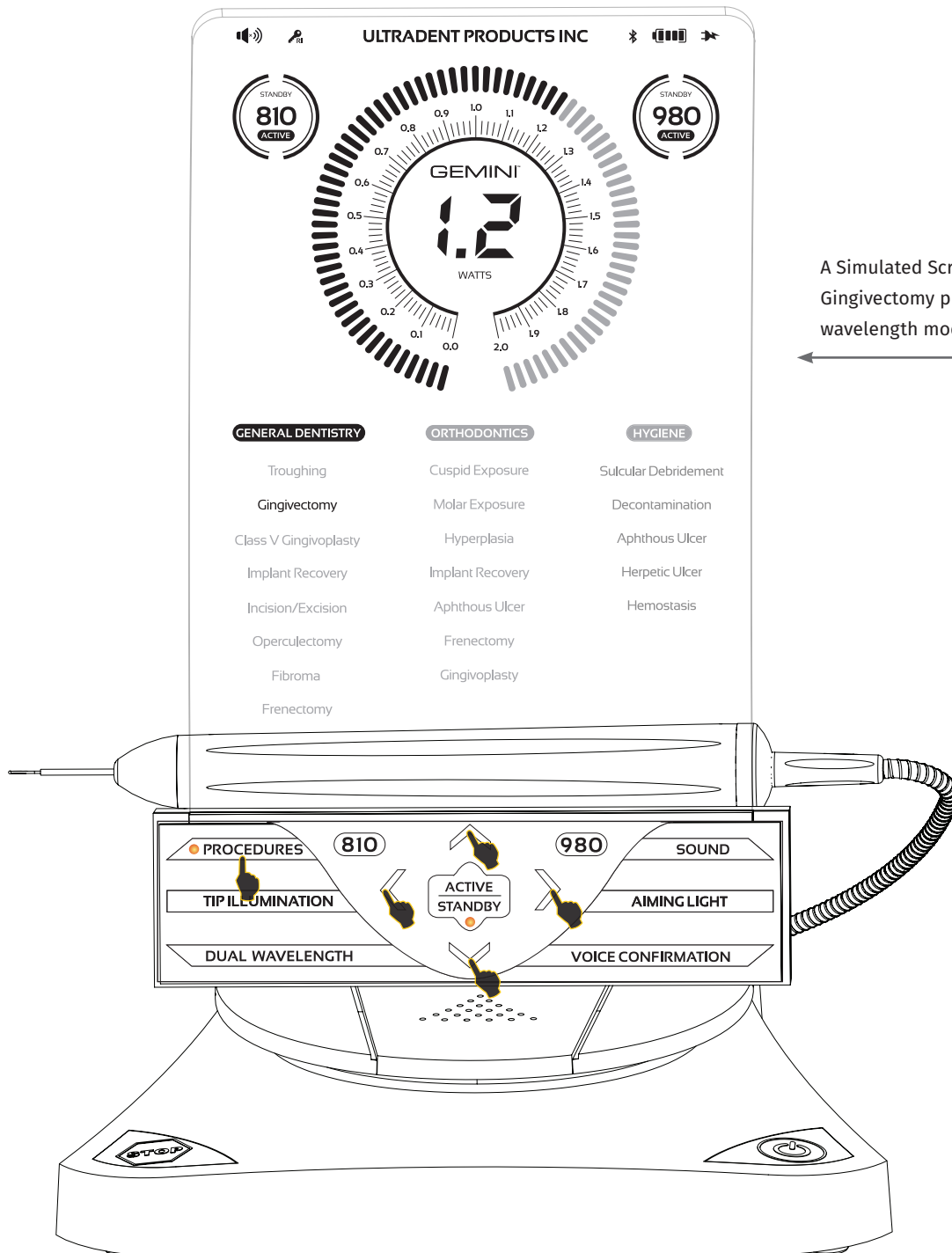

A Simulated Screen showing the preset Gingivectomy procedure and dual wavelength mode selected.

CONTROLS, OPERATION & USE

07 - PRESET PROCEDURE SETTINGS

The Gemini 810 + 980 diode laser has 20 preset procedures listed under three categories: General Dentistry, Orthodontics, and Hygiene. Within each category are the most commonly used procedures with suggested power settings. Always use the minimum amount of power necessary to perform a particular procedure. Manual power adjustment may be necessary depending on patient and procedural needs.

General Dentistry	Contact	810	980	DUAL WAVELENGTH	
Troughing	Yes	0.9 W	1.2 W	1.1 W	Initiated Tip
Gingivectomy	Yes	1.0 W	1.3 W	1.2 W	Initiated Tip
Class V Gingivoplasty	Yes	0.8 W	1.0 W	0.9 W	Initiated Tip
Implant Recovery	Yes	1.3 W	1.7 W	1.5 W	Initiated Tip
Incision/Excision	Yes	1.0 W	1.3 W	1.2 W	Initiated Tip
Operculectomy	Yes	1.4 W	1.8 W	1.6 W	Initiated Tip
Fibroma	Yes	1.0 W	1.3 W	1.2 W	Initiated Tip
Frenectomy	Yes	1.1 W	1.4 W	1.3 W	Initiated Tip
Orthodontics	Contact	810	980	DUAL WAVELENGTH	
Cuspid Exposure	Yes	0.8 W	1.0 W	0.9 W	Initiated Tip
Molar Exposure	Yes	1.0 W	1.3 W	1.2 W	Initiated Tip
Hyperplasia	Yes	1.0 W	1.3 W	1.2 W	Initiated Tip
Implant Recovery	Yes	1.1 W	1.4 W	1.3 W	Initiated Tip
Aphthous Ulcer	No	0.6 W	0.8 W	0.7 W	Uninitiated Tip
Frenectomy	Yes	1.0 W	1.3 W	1.2 W	Initiated Tip
Gingivoplasty	Yes	0.9 W	1.2 W	1.1 W	Initiated Tip
Hygiene	Contact	810	980	DUAL WAVELENGTH	
Sulcular Debridement	Yes	0.4 W	0.5 W	0.4 W	Initiated Tip
Decontamination	Yes	0.7 W	0.9 W	0.8 W	Uninitiated Tip
Aphthous Ulcer	No	0.6 W	0.8 W	0.7 W	Uninitiated Tip
Herpetic Ulcer	No	0.6 W	0.8 W	0.7 W	Uninitiated Tip
Hemostasis	Yes	0.8 W	1.0 W	0.9 W	Initiated Tip

All Power Settings are shown in Average Power.

CONTROLS, OPERATION & USE

08 - CUSTOMIZING PRESET PROCEDURE SETTINGS

The Gemini laser's preset procedure settings can be customized. To save your own procedure setting, press PROCEDURES once to bring up preset procedures on the display and navigate to the procedure you would like to customize.

When a particular procedure is highlighted, press and hold PROCEDURES for 3 seconds.

You will hear two audible beeps and the Power Indicator and Power Dial will start flashing on the display. Use UP/DOWN or LEFT/RIGHT to adjust the new average power to the desired setting.

To save the setting, press and hold the PROCEDURES key for 3 seconds. You will hear two audible beeps when the setting has been saved.

To reset all preset procedure settings to the factory default, press PROCEDURES once to bring up preset procedures on the display, then press and hold the PROCEDURES key for 10 seconds. You will hear three audible beeps when the settings are reset.

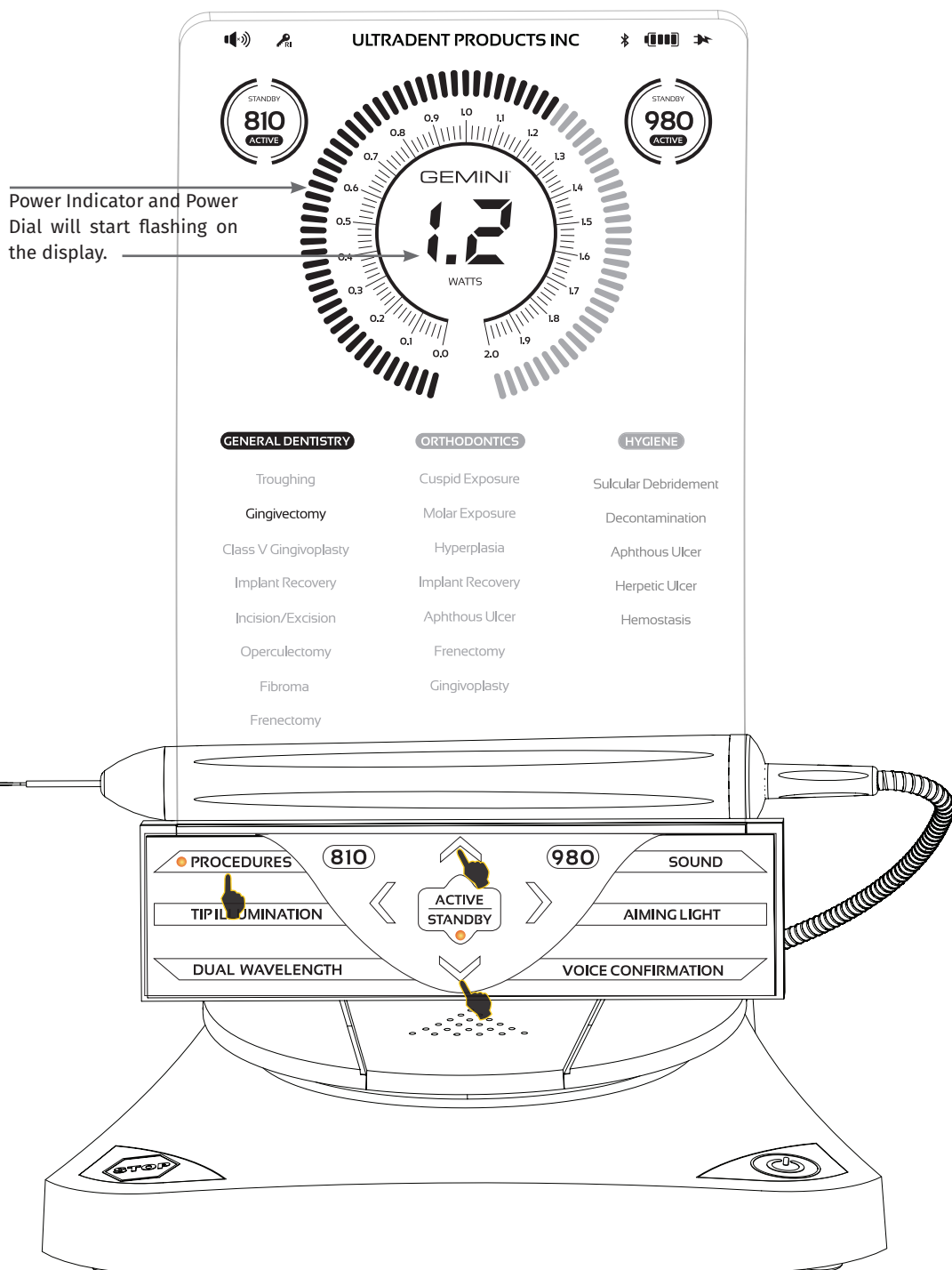

○ PROCEDURES
Hold 3 seconds = Customize / Save
Hold 10 seconds = Factory Reset

CONTROLS, OPERATION & USE

09 - DISPOSABLE TIP OPERATION

The disposable fiber tip is relatively flexible, but can be broken if bent at an angle that is too sharp. Use the provided Bending Tool to bend the tip to the desired angle. Do not bend the tip any more than the Bending Tool allows.

Protein debris from gingival tissue accumulates on the fiber tip during surgery, and the extreme heat that develops will deteriorate the optical efficiency. Fibers can fracture if a blackened area greater than 3–4 mm develops.

Replace the disposable, single-use fiber optic tip as necessary and for each new patient. The tips are provided in a sealed package. Each tip contains a pre-cleaved, pre-stripped piece of fiber. They are designed for single-use only and must be discarded after use.

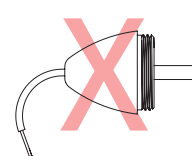
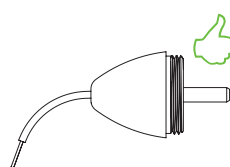
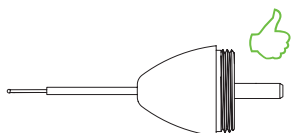
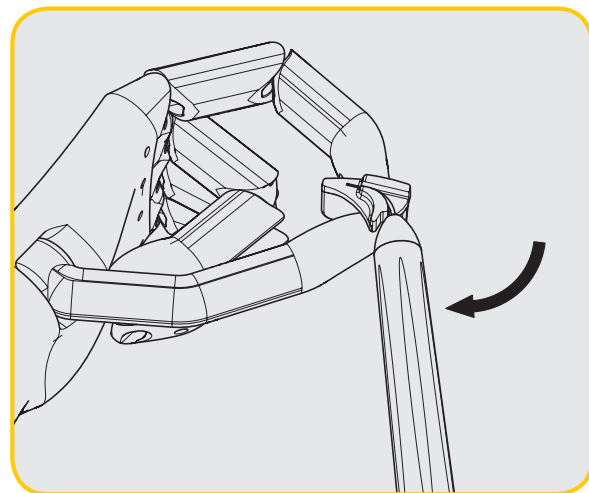
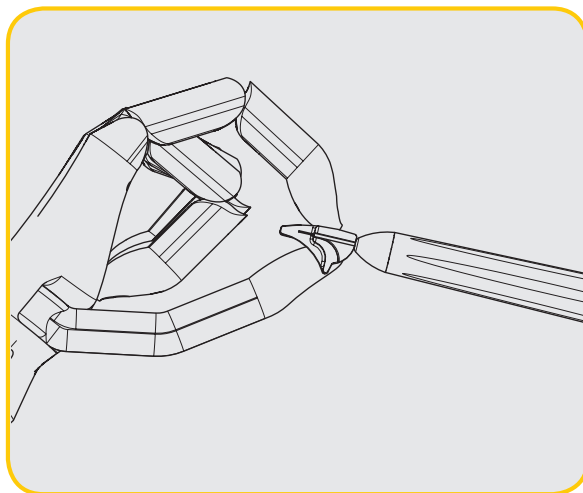
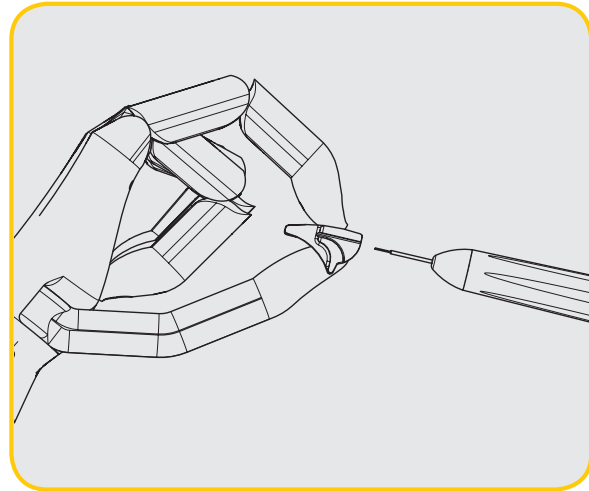
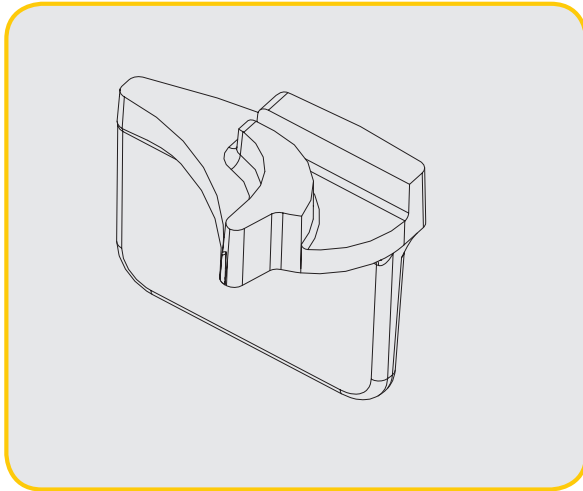

CONTROLS, OPERATION & USE

10 - INITIATION OF FIBER TIPS

Gemini's 5mm single-use fiber tips are unique in that they come pre-initiated. That means there is black pigment added to the end of each fiber tip to help focus laser energy at the tip. All procedures that require the removal or cutting of soft tissue require an initiated tip. There are some procedures that call for an un-initiated tip, such as Aphthous Ulcer treatment where no tissue is being removed.

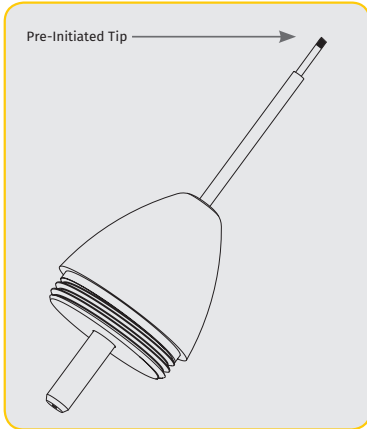

To ensure that the tip stays initiated when wiping the tip with isopropyl alcohol before a procedure, activate and fire the laser at 1 watt of average power for 1-2 seconds prior to wiping the tip. This action will ensure that the pre-initiation does not wipe off during the cleaning process.

When a procedure calls for an uninitiated tip, simply rub off the pigment at the end of the Fiber Tip with gauze and isopropyl alcohol. This pigment removal must occur before firing the laser.

Gemini's 7mm single-use fiber tips come uninitiated.

Laser procedures that do not remove tissue, such as decontamination or the treatment of aphthous ulcers, do not require the laser tip to be initiated. One way to initiate the tip is to rub the tip on articulating film while firing the laser on a low power setting. **IMPORTANT NOTE:** Not all soft-tissue procedures require an initiated—or darkened—tip and contact with tissue. Those procedures that do not require tissue contact will use a fiber tip that is **NOT** initiated, because to be effective in non-contact mode, laser energy must flow unimpeded from the tip into the target tissues. Follow the procedure above to uninitiate a fiber tip.

11 - TIP ILLUMINATION

The Gemini 810 + 980 diode laser's handpiece is equipped with a tip illumination light to provide better visibility of the surgical site during treatment. To toggle the light intensity between LOW, HIGH, and DISABLED, touch the TIP ILLUMINATION selection on the keypad. The LED will only stay on for 3 seconds when not in active mode.

Please note that the tip illumination light will only be permanently visible when laser is in Active mode.

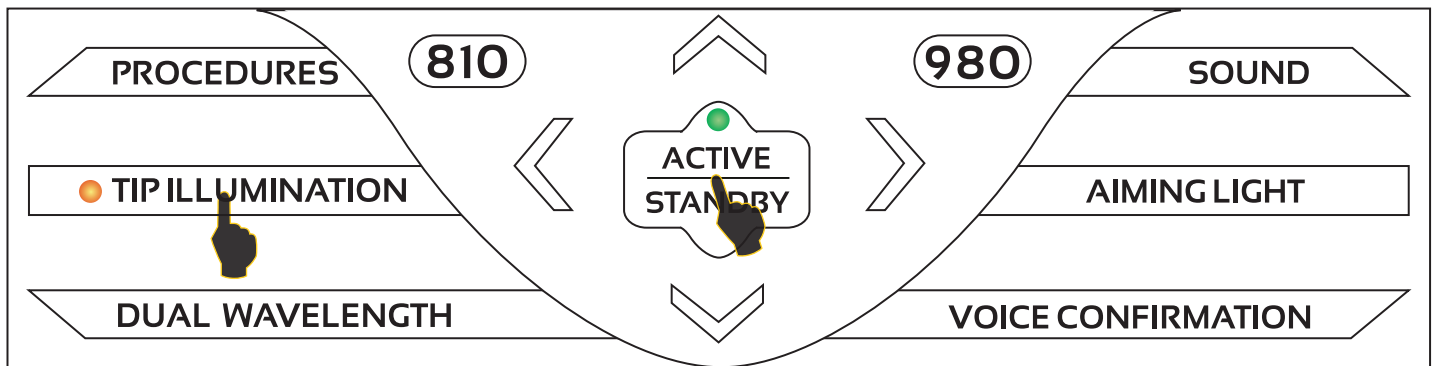

CONTROLS, OPERATION & USE

12- SOUND

The system's default sound volume level is Medium. Touch the SOUND selection on the keypad to bring up the sound levels. Adjust the sound level by touching the UP and DOWN arrow on the keypad. To exit, touch any key on the keypad. This will confirm and save your selection. The system remembers the last used sound setting when it is powered on.

Voice Confirmation can be turned ON and OFF by touching the voice confirmation selection on the keypad.

13 - AIMING LIGHT

The system's default aiming light level is Medium. Touch the AIMING LIGHT selection on the keypad to bring up the aiming light levels. Adjust the aiming light level by touching the UP and DOWN arrow on the keypad. To exit, touch any key on the keypad. This will confirm and save your selection. The system remembers the last used aiming light setting when it is powered on.

Target icon







CONTROLS, OPERATION & USE

14 - BATTERY and BATTERY LEVEL INDICATIONS

The Gemini 810 + 980 diode laser is equipped with a powerful nano-core lithium polymer battery capable of delivering a full day of laser usage and lasting several days in Standby mode. Simply connect the provided power supply to the rear of the unit and charging will start immediately.

It is recommended to fully charge the laser unit prior to initial use after unpacking.

The battery level indicator is located at the upper right corner of the display and shows battery percentage remaining.

 100%	Standby Time: 7 Days	Usage Time: 1.5Hours
 75%	Standby Time: 5 Days	Usage Time: 1.0Hours
 50%	Standby Time: 3 Days	Usage Time: 30 min
 25%	Standby Time: 1 Day	Usage Time: 15 min
 "Please connect power supply" reminder.		
 0%	Minimum of 60 minutes of charging is required before first use	

- Standby time refers to when the unit is off and not being used.

- Usage time refers to constant use without interruption

15 - POWER SUPPLY

Use only the provided 13V, 4A AC/DC power supply for charging the system battery and as an alternate laser power source. During initial setup, use the AC/DC power supply for one full hour to fully charge the battery.

Plug the power supply into an AC outlet and connect to the corresponding connector on the rear of the laser unit. Only use the power supply provided with the system.

WARNING: To avoid the risk of electric shock, this equipment must only be connected to a supply main with a protective earthing conductor.

CONTROLS, OPERATION & USE

16 - FIBER WRAPPING

A fiber wrapping system was built within the laser unit in order to provide a safe and convenient way to manage and store the optical fiber system. To store the fiber properly, always wrap in a clockwise direction to protect and store the fiber optic cable when not in use.

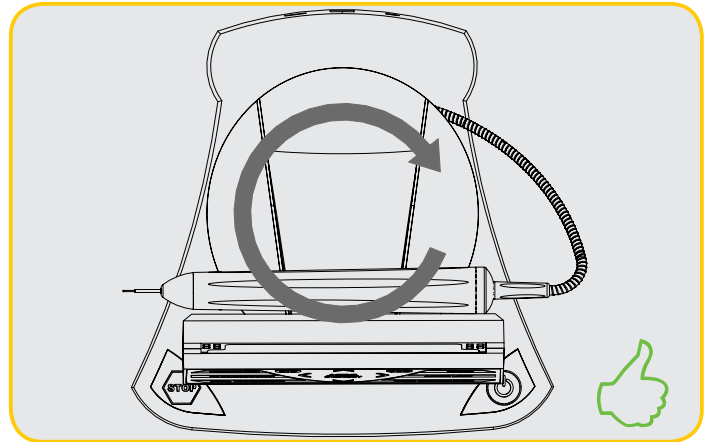
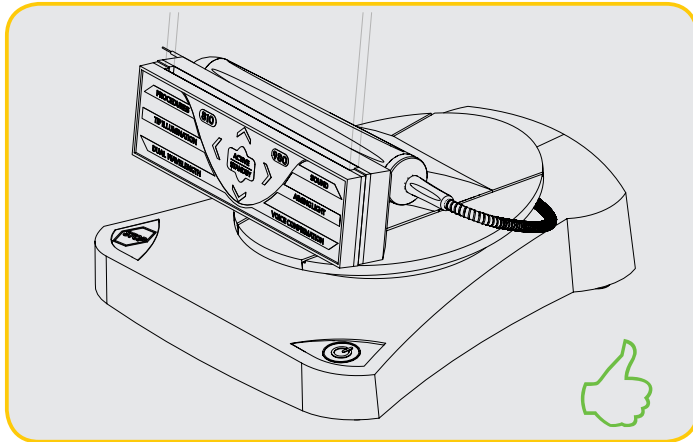

CAUTION: AVOID DAMAGING THE FIBER. Do not wrap the fiber in a counter-clockwise direction. Doing so will possibly damage the optical fiber, preventing the use of the laser.

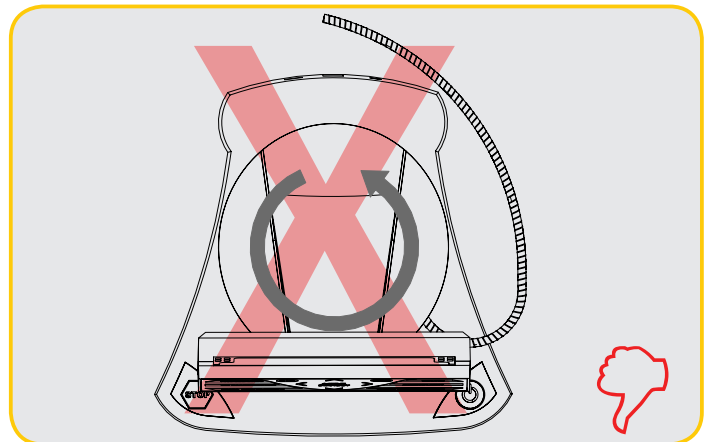
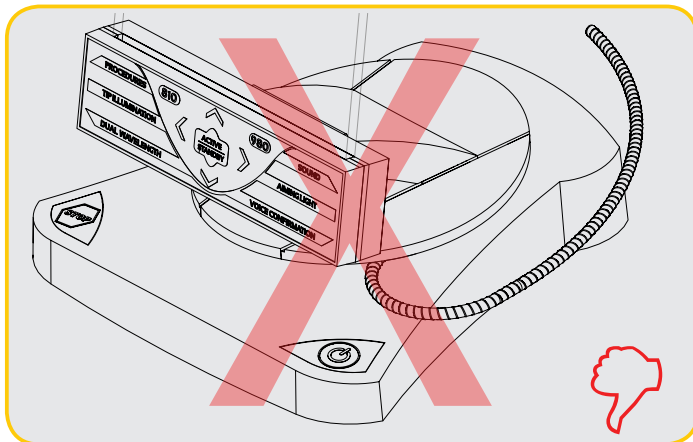

The fiber optic cable conducts laser energy from the laser diodes to the target tissues. These fibers are made of a thin glass silica. Note that there are potential hazards when inserting, steeply bending, or improperly securing the fiber optic tips to the handpiece. Failure to follow these recommendations may lead to damage of the fiber or delivery system, and/or harm to the patient, staff, or laser operator.

CONTROLS, OPERATION & USE

17 - HANDPIECE MAGNET

The Gemini 810 + 980 diode laser is designed with a strong magnet that will secure the surgical handpiece in place when the laser is not in use. Gently place the handpiece behind the transparent display over the neck of the laser unit and the magnet will hold the handpiece in place.

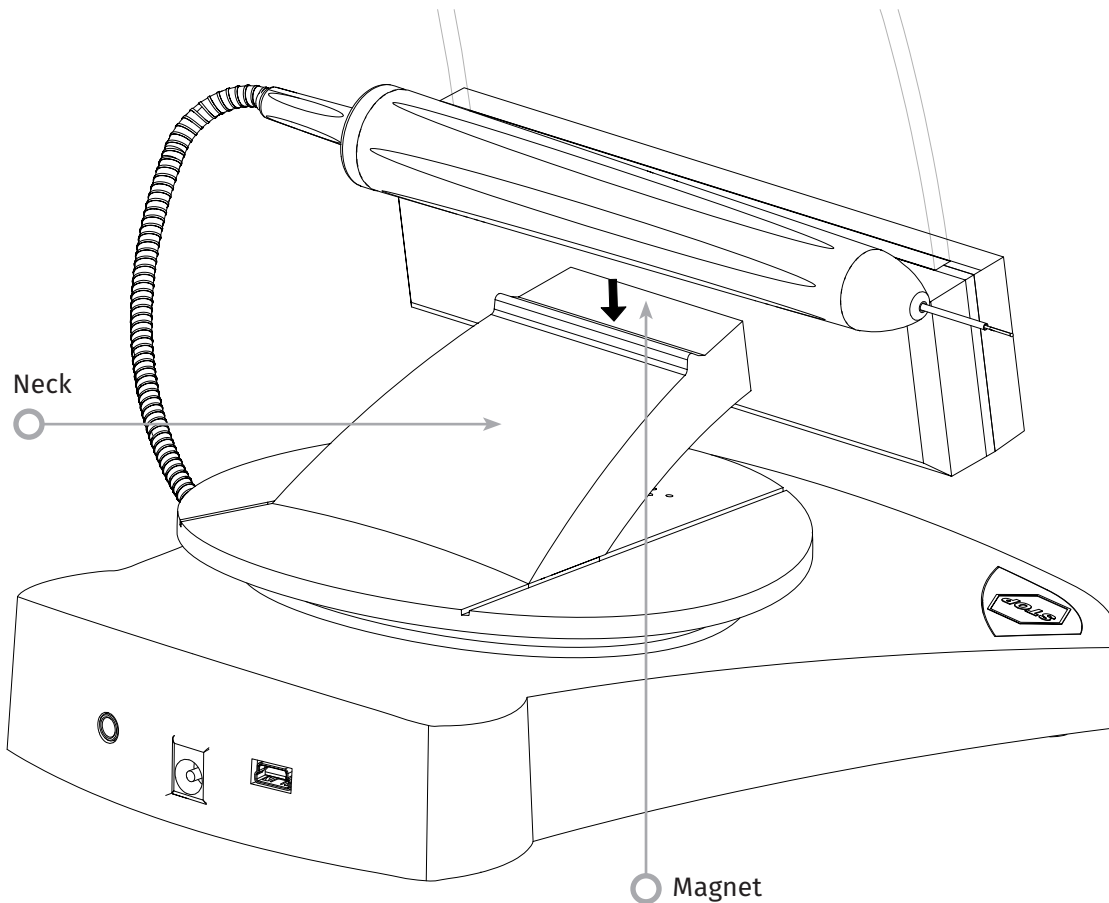

18 - OPERATING MODE

The Gemini 810 + 980 diode laser will only deliver energy in pulsed “temporal emission mode” and is optimized to efficiently deliver energy and provide the operator with ideal control of target tissue temperatures. The pulse width is fixed and not user adjustable. The operator will only need to adjust the laser wavelength and average power.

CONTROLS, OPERATION & USE

19 - EMERGENCY STOP

The Gemini 810 + 980 diode laser can be immediately deactivated in any mode, at any time, and at any power setting by pressing the red STOP button located in the front left of the system.

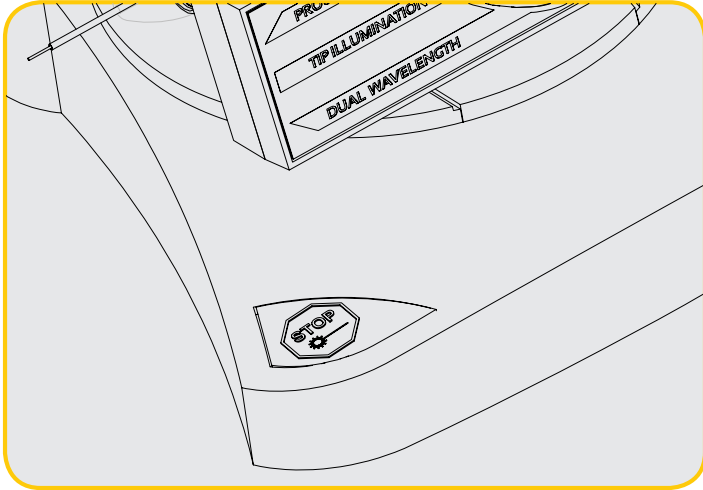

20 - REMOTE INTERLOCK (Switch not Included)

The Gemini 810 + 980 diode laser provides a remote interlock feature that enables a clinician to establish a dedicated laser treatment room with a remote interlock connector. A switch on the entrance door is attached and is electronically wired into the laser unit via 2.3 mm plug jack. When the door to the room is opened, the connector/switch provides an electrically open circuit that deactivates laser emissions. To use the remote interlock feature, an interlock connector/switch and cable must be purchased. Contact the manufacturer for assistance.

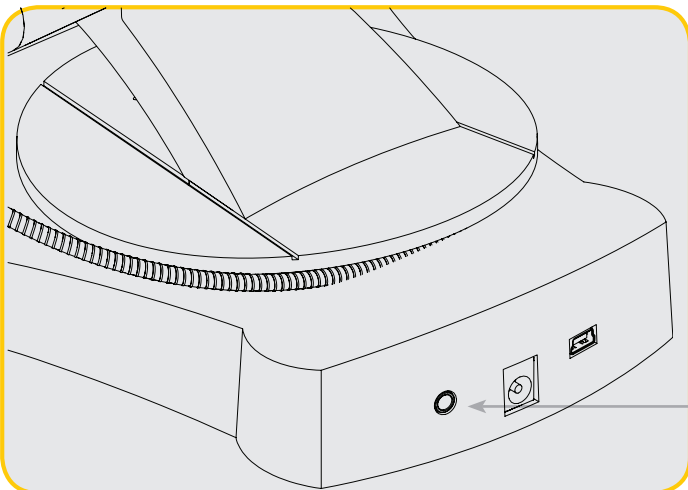

 Remote Interlock Symbol as it appears on display

 2.3 mm Plug Port

CONTROLS, OPERATION & USE

21 - TRANSPARENT ELECTROLUMINESCENT DISPLAY

The Gemini 810 + 980 diode laser is designed with a unique transparent electroluminescent display, which produces high-resolution images that can be viewed from a field of vision up to 170 degrees.

The transparent display was specially designed with over 80% transparency and an arch of 32 degrees for optimal viewing angle from any direction. The light is generated by a thin film—less than a micron thick—of specially designed electroluminescent phosphor.

SPECIFICATIONS

Display type:	Electroluminescent
Transparency:	92%
Brightness:	300 cd/m ²
Color:	Broadband Yellow
Peak Wavelength:	582 nm
Voltage:	~180V AC
Response time:	1.8 ms
Glass type:	Float Glass
Glass thickness:	1.1 mm fused
Thin Film Thickness:	1 micron

DO NOT GRAB DISPLAY THIS WAY

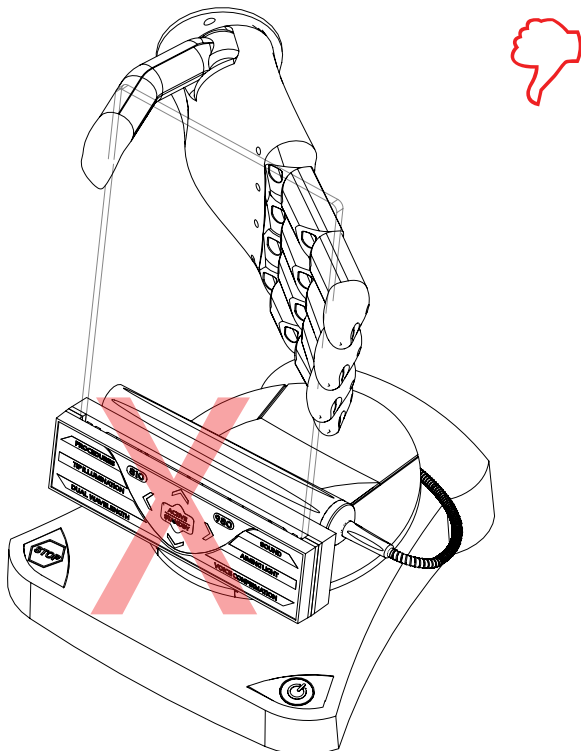

GRAB UNIT BY THE NECK

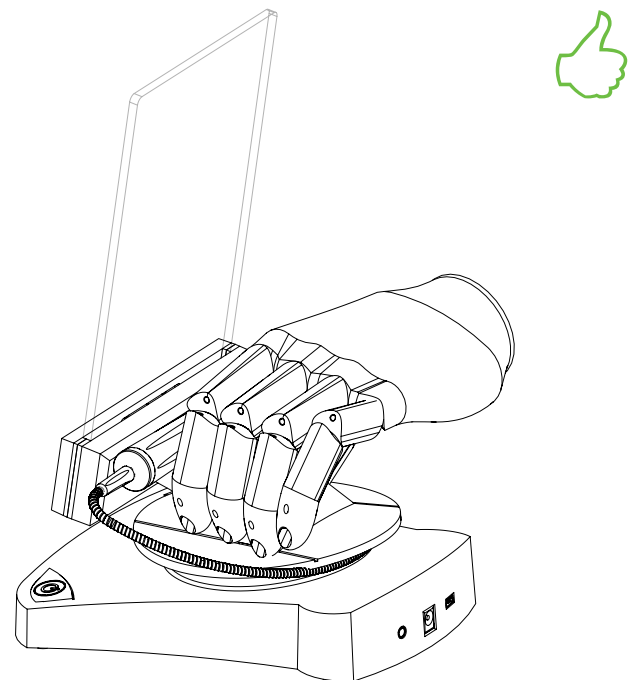

CLEANING AND STERILIZATION PROCEDURES

GUIDELINES

The Gemini 810 + 980 diode laser is not supplied in sterile condition, nor must it be sterilized before use with the exception of the handpiece. The following cleaning and sterilization procedures are recommended before the initial use and after each subsequent use:

1. The disposable fiber tips are supplied non-sterile by the manufacturer and should be wiped with Isopropyl alcohol wipes by the operator prior to use. The tips are to be discarded in an infectious waste container (SHARPS) after each use. There is no re-use or re-processing procedure indicated for the disposable fiber tips.
2. The aluminum handpiece is also provided non-sterile by the manufacturer and should be cleaned and sterilized prior to initial use and after each use following these instructions:

CLEANING

Warning: The Gemini 810 + 980 diode laser and its components **cannot be cleaned with an automated cleaning process.**

The cleaning process is intended to remove blood, protein, and other potential contaminants from the surfaces and crevices of reusable accessories. This process may also reduce the quantity of particles, microorganisms, and pathogens present. Cleaning must be performed within a maximum of 1 hour after the procedure and always prior to sterilization:

1. After use, carefully remove the disposable fiber tip from the handpiece and dispose of in an infectious waste container (SHARPS).
2. Clean the handpiece and attached fiber cable by using one CaviWipes® towelette, or equivalent product, to completely pre-clean exposed areas of all gross debris. Be sure to wipe the threaded area where the disposable tip attaches.
3. Remove the handpiece shell following the instructions on the next page. Use a fresh towelette to pre-clean the newly exposed handpiece shell thread and the end cap (starting at the o-ring and wiping towards the fiber cable).
4. Use a new towelette to thoroughly wet all pre-cleaned areas, keeping all areas wet for 2 minutes at room temperature (68° F/20° C). Repeated use of towelettes may be required to ensure that the surfaces remain visibly wet.
5. Visually inspect the handpiece to ensure there is no visible debris remaining. If necessary, continue wiping with CaviWipes until all visible debris is removed.
6. Wipe all exposed areas of the handpiece with isopropyl alcohol wipes to remove any residue left by the CaviWipes®

STEAM STERILIZATION

The steam sterilization process is intended to destroy infectious microorganisms and pathogens. Always perform the sterilization procedure immediately after cleaning and prior to use, and only use FDA-cleared (USA) or CE-marked (Europe) sterilization accessories such as sterilization pouches and autoclave trays.

CLEANING AND STERILIZATION PROCEDURES

1. Place the handpiece shell in a separate single-wrap, self-seal autoclave pouch.
2. Place on an autoclave tray with paper side up; do not stack other instruments on top of the pouch.
3. Place the tray inside the autoclave chamber and set the cycle to 135° C (275° F) for a minimum of 15 minutes, with a dry time of 30 minutes.
4. Once the cycle is completed, remove the tray and let the sterilized item cool and dry. The handpiece must remain in the sterilization pouch until used in order to maintain sterility.
5. Reassemble the handpiece following the instructions below.

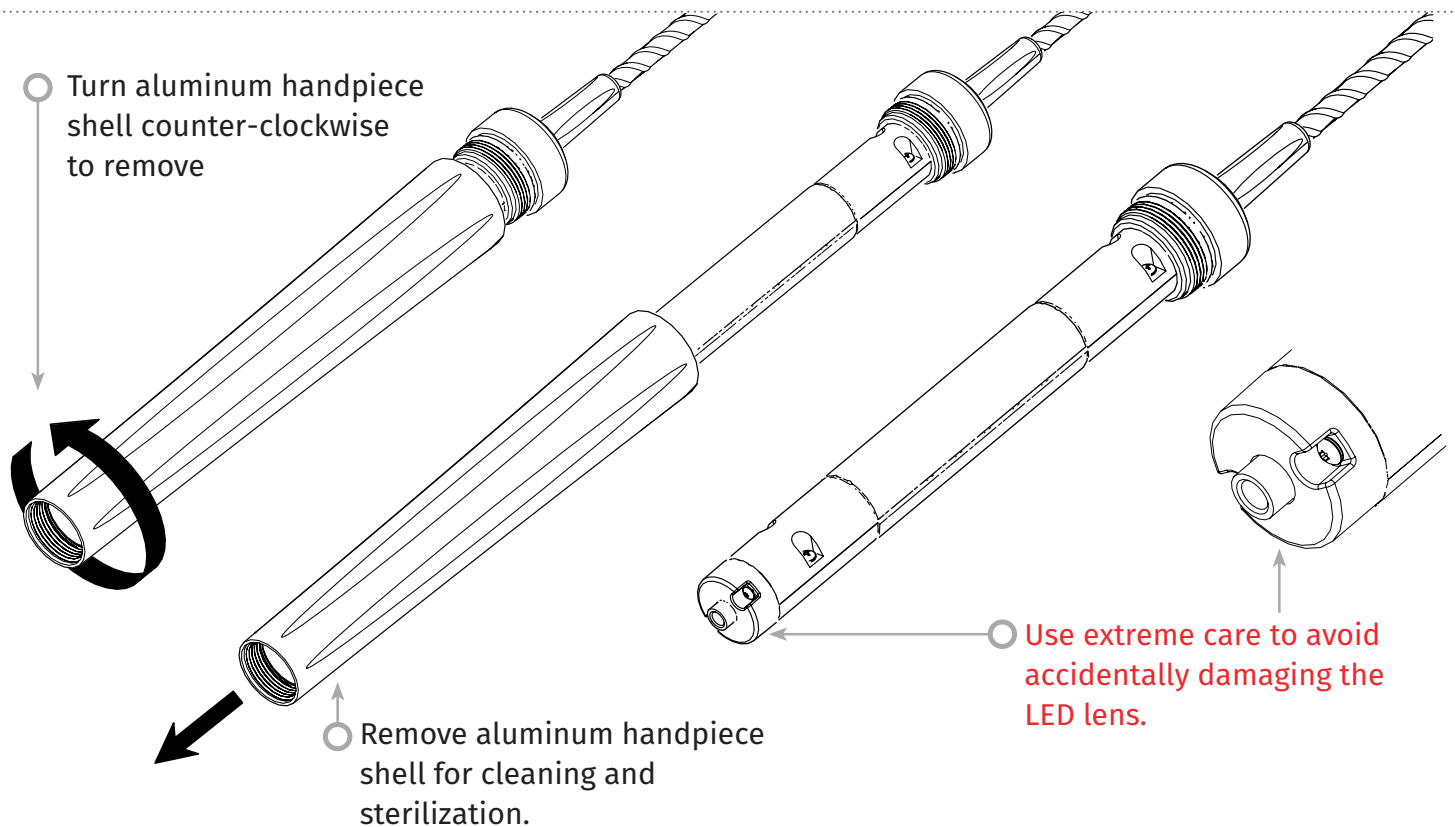

To reassemble, slide the handpiece shell onto the handpiece body and turn clockwise to tighten.

NOTE: The exterior of the laser unit is not routinely contaminated by procedures. The keypad and electroluminescent display should be covered with a protective clear adhesive barrier film, replaceable after each patient. If the exterior of the laser unit becomes contaminated, it should be wiped down with CaviWipes®, or equivalent product, then re-covered with a new protective plastic cover.

DO NOT spray any disinfectant directly on the laser unit, because it could damage the transparent electroluminescent display.

DO NOT use abrasive materials to clean the laser or the display.

NEVER point the laser tip directly at the face, eyes, or skin of anyone while emitting energy.

PROCEDURAL RECOMMENDATIONS

GUIDELINES

The following procedure guidelines are provided as a guide only and have been developed based on information provided by experienced laser users and educators. Always review the patient's history to evaluate possible contra-indication for use of local anesthesia or other complications.

All clinical procedures performed with the Gemini 810 + 980 diode laser must be subjected to the same clinical judgment and care as with traditional techniques and instruments. Patient risk must always be considered and fully understood before clinical treatment. The clinician must completely understand the patient's medical history prior to treatment.

INDICATIONS FOR USE

The particular and specific intended use of the Gemini 810+980 Diode Laser is to remove, ablate and coagulate tissue, mainly used for dental surgical procedures and is marketed as a dental soft tissue surgical product. The main intended users for this particular device are general dentists, oral surgeons, orthodontists performing procedures where tissue needs to be removed, ablated or coagulated.

FACILITY & ENVIRONMENTAL CONSIDERATIONS

GUIDELINES

In addition to receiving proper training in the use of soft-tissue dental lasers, users should be familiar and experienced with these procedures using electrosurgical devices or traditional instruments before performing them on patients with the Gemini 810 + 980 diode laser. Non-experienced users should seek appropriate training guidance before attempting clinical treatments with the Gemini laser unit.

In order to ensure the safe use of the Gemini 810 + 980 diode laser in your facility, please check to make sure that the proposed location is compatible with the specifications listed below.

POWER REQUIREMENTS

External AC/DC Power Supply:

Input Power - 110–120 VAC @ 60 Hz 700mA; 220–240 V AC @ 50Hz 350mA

Output Power – 6.0W + 13V DC at 4A maximum

HEATING AND VENTILATION

Operating environmental conditions to be within 10°-40°C (50°-104°F), and 95% relative humidity or less. Transportation and storage environmental conditions to be within -20° to 50°C (-4° to 122°F), and relative humidity of 10% to 95% or less. Atmospheric pressure to be within 50kPa–106kPa in operating, transportation and storage conditions.

COMBUSTIBLE CHEMICALS AND GASES

All gases that are combustible or support combustion and are used in the operatory area where the Gemini 810 + 980 diode laser is being operated must be turned off during the procedure. Cleaning supplies or other flammable chemical compounds should be stored in an area away from the surgical site in order to avoid possible combustion. Do not use in the presence of supplemental therapeutic oxygen supplies for patients with respiratory or related diseases.

PLUME EVACUATION

Plume evacuation should be addressed when vaporizing tissues. A high volume vacuum system should be used and 0.1 micron or less high filtration masks that are suitable for virus and bacterial control should be worn by clinicians.

OPERATORY ACCESS DURING LASER USE

Access to the treatment area should be restricted while the lasers are in use. A sign indicating “LASER IN USE” should be placed in a designated area adjacent to the treatment area entry location.

GENERAL SAFETY CONSIDERATIONS

GUIDELINES

Safe use of the Gemini 810 + 980 diode laser is the responsibility of the entire dental team including the doctor, any system operators, and the dental office safety officer.

MARKETING REQUIREMENTS REGARDING MEDICAL DEVICE SAFETY (USA)

The United States Food and Drug Administration (FDA) has control over the sale and use of all medical devices including the Gemini 810 + 980 diode laser. Manufacturers of products subject to performance standards under the Federal Food, Drug, and Cosmetic Act, Chapter V, Subchapter C - Electronic Product Radiation Control are required to certify compliance with the regulations and furnish various reports to the Center for Devices and Radiological Health (CDRH).

For manufacturers of medical lasers (such as the Gemini 810 + 980 diode laser system), additional review by the FDA of the safety and effectiveness of the device is required. Companies who intend to market a medical laser or equivalent device must receive authorization from the FDA before the device is permitted into commercial distribution. The premarket notification (510k) process used for the Gemini 810 + 980 diode laser system is applicable for devices that are documented to be substantially equivalent to existing legally marketed Class II devices.

STATUTORY LICENSURE FOR DENTAL LASER USE

Usually, states or provinces do not have a specific licensure requirement for use of surgical laser devices by dentists. Many states do, however, require hygienists who will be using lasers to attend licensure training that includes both a lecture and hands-on experience.

The license applicants are then required to pass a proficiency test for certification prior to using lasers. These courses are usually taught by members of the Academy of Laser Dentistry who possess instructor credentials. Such training would be appropriate for use of the Gemini 810 + 980 diode laser system.

OSHA PROVISIONS

Worker safety is the responsibility of the employer and is regulated by OSHA (Occupational Safety and Health Administration), a division of the U.S. Department of Labor. OSHA recognizes ANSI standard Z136.1 as a source for analyzing safety with respect to medical lasers.

For more information, see OSHA Technical Manual (TED1- 0.15A) Section III, Chapter 6, 1999. A safety program is recommended for the safety of your patients and office staff in connection with the use of the laser. It is also recommended to check and comply with applicable state and provincial safety and health organization requirements.

GENERAL SAFETY CONSIDERATIONS

CSA PROVISIONS

This device is to be installed and operated according to the Canadian Standards Association CAN/CSA-Z386-08 provision for the safe use of the entire laser apparatus. This standard provides guidance for the Health Care Laser System (HCLS), and is intended for use by all personnel associated with the installation, operation, calibration, maintenance, and service of the HCLS. This standard includes engineering, procedural and administrative controls, and laser safety training necessary for the safety of patients and health care professionals.

CONTRA-INDICATIONS

Exercise caution for general medical conditions that might contra-indicate a local procedure. Such conditions may include allergy to local or topical anesthetics, heart disease, lung disease, bleeding disorders, and immune system deficiency, or any medical conditions or medications that may contra-indicate use of certain light/laser type sources associated with this device. Medical clearance from patient's physician is advisable when doubt exists regarding treatment.

The Gemini 810 + 980 diode laser is not indicated for hard tissue procedures. The Laser is attracted to melanin, hemoglobin, and, to some extent, water. Avoid prolonged exposure of the energy when working in and around the cervical areas of the tooth. Due to the thin layer of enamel in this area, energy may be absorbed by the hemoglobin in the pulp and pulpal hyperemia may occur. Extended exposure to such energy could cause patient discomfort and even lead to possible pulpal necrosis.

ADVERSE EFFECTS

If used properly, there are no known adverse effects of using the Gemini 810 + 980 diode laser. Please thoroughly read and understand all warning, precautions, and contra-indications in this manual prior to use.

GENERAL SAFETY CONSIDERATIONS

EYE AND SKIN PROTECTION

While the Gemini 810 + 980 diode laser is in use, doctors, system operators, auxiliary staff, patients, and anyone in the operatory must wear the appropriate safety eyewear that has been designed for use with the wavelengths of 800 nm and higher that are associated with lasers. Eye protection must conform to Specification DIN EN207 Annex II of the Directive 89/686/EEC with optical density of OD+5 for the wavelength range of 800 nm–1000 nm such as NoIR Laser Company filter model CYN.

Nominal Ocular Hazard Distance (NOHD) is the distance from the source of laser emission to the point where it no longer exceeds its Maximum Permissible Exposure (MPE – highest level of laser radiation to which a person may be exposed without hazardous effects or adverse biological changes in the eyes or skin). The Nominal Hazard Zone (NHZ) is the space within which the level of direct, reflected, or scattered radiation during normal operation exceeds the appropriate MPEs. The outer limit of the NHZ is equal to the NOHD. The NOHD for persons wearing recommended safety glasses is shown in Table 1 below.

Table 1: NOHD (INCHES/CM)

RADIATION SOURCE	MPE mW cm ²	Divergence Angle	Without Eye Protection	With Recommended Eye Protection
FIBER OPTIC TIP (DIRECT)	1.66	22° (+/- 1°)	104 in 265 cm	1.04 in 2.65 cm

Never point the Laser tip directly at the face, eyes or skin of anyone while emitting energy.

GENERAL SAFETY CONSIDERATIONS

EMERGENCY SHUTDOWN OPTIONS:

Perform any of these actions to terminate laser emissions in the event of a real or perceived emergency:

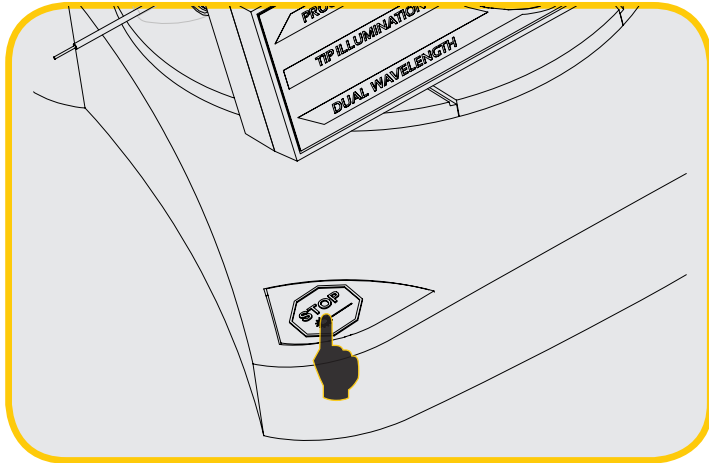

Press the emergency "STOP" button.

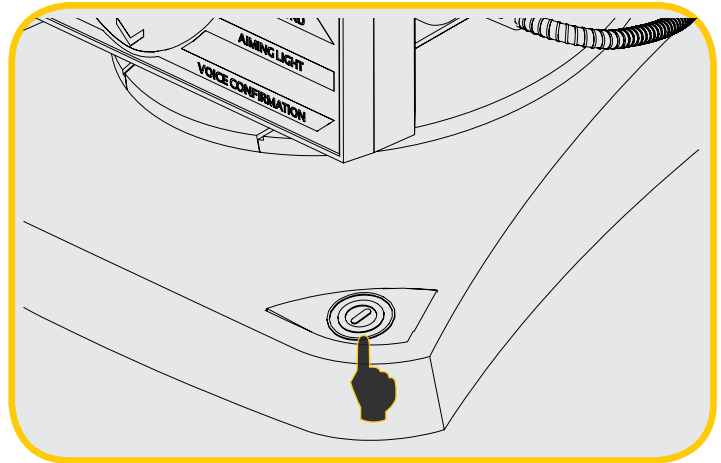

Press the "ON/OFF" button.

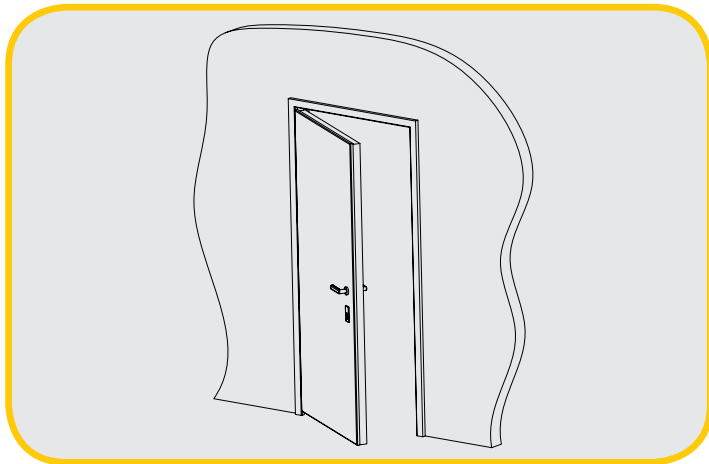

Remote Interlock open circuit deactivates the Laser



Touch the ACTIVE/STANDBY keypad selection

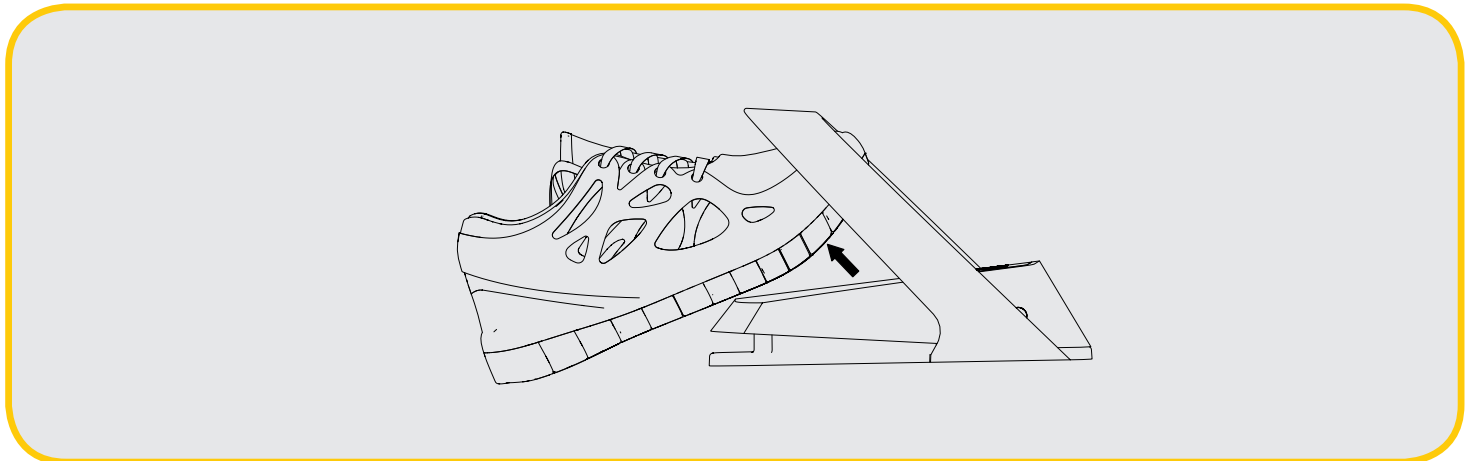

Release your foot from the Activation Pedal

SYSTEM SPECIFICATIONS

Gemini 810 + 980 Diode Laser

Dimensions of Laser Unit:	6.7" (L) x 6.6" (W) x 10.1" (H) - 17.2 cm (L) x 17.0 cm (W) 25.7 cm (H)
Dimensions of Foot Pedal:	6.1" (L) x 5.0" (W) x 4.1" (H) - 15.5 cm(L) x 12.7 cm (W) 10.4 m (H)
Weight:	2.2 lbs - 1.0 Kg
Laser classification:	Class IV laser device
Delivery system:	Optical Fiber
Wavelength:	810 nm or 980 nm \pm 10 nm Dual Wavelength \pm 10 nm (50% @ 810 nm / 50% @ 980 nm)
Maximum power:	810 nm @ 2.0 Watts \pm 20% 980 nm @ 2.0 Watts \pm 20% Dual Wavelength @ 2.0 Watts \pm 20%
Aiming beam wavelength:	650 \pm 10 nm
Aiming beam power:	5mW max
Beam divergence:	617 mrad
Power range:	0.1 Watt to 2.0 Watts Average
Pulse frequency:	50 Hz
Pulse width :	Variable
Duty cycle:	Variable
Voice confirmation:	YES
Power requirements:	100-240 VAC @ 50 to 60 Hz - 13V
Current:	4.0 Amps
Battery:	11.1V Rechargeable Lithium Ion
Wireless frequency:	Bluetooth at 2.4 GHz
Maximum Operating Altitude:	5,000 meters or 16,404 feet

THE GEMINI 810 + 980 DIODE LASER COMPLIES WITH THE FOLLOWING

- IEC 60825-1
- IEC 60601-1-2
- 21 CFR 1040.10 and 1040.11
- EN/ES 60601-1
- IEC 60601-2-22
- FCC parts 15 and 18 (47 CFR)

SERVICE AND TROUBLESHOOTING

CALIBRATION

The Gemini 810 + 980 diode laser uses solid-state circuitry to continuously monitor power output and adjusts the power supplied to the laser diodes to maintain the output at the operator- defined setting. If the output levels are more than $\pm 20\%$ of the set value, the unit will shut off power to the laser diode and provide an Error Message Alert to the operator.

If this happens, the unit should be turned off and allowed to sit for about five (5) minutes, then turned on again. If the laser performs when re-tried, the microprocessor has been able to make adjustments and the unit will function. If the unit fails to fire when re-tried, the device will need to be sent for re-calibration by the manufacturer.

Re-calibration is recommended at a minimum of one time per year in order to maintain the required accuracy of output power versus displayed power. The Gemini 810 + 980 diode laser may be returned to the manufacturer for recalibration. Alternatively, a calibrated laser power meter, approved for use with 810 nm-980 nm laser devices, may be purchased to check laser output power. The power meter will also need to be calibrated at intervals recommended by the power meter manufacturer.

Laser output should be checked at 0.5, 1.0, 1.5 and 2.0 watts. The power meter display should be within 20% of the meter reading. If not, replace the fiber tip. If the output is still outside the 20% tolerance, the system must be returned to the manufacturer for re-calibration. The laser unit cannot be re-calibrated by the user or service contractor and this must not be attempted.

WIRELESS INTERFERENCE

This equipment has been tested and found to comply with the limits for Class B Digital Device, pursuant to Part 15 of the FCC Rules. These limits are designed to provide reasonable protection against harmful interference in a residential installation. This equipment generates and can radiate radio frequency energy and, if not installed and used in accordance with the instructions, may cause harmful interference to radio communications.

However, there is no guarantee that interference will not occur in a particular installation. This equipment may cause harmful interference to radio or television reception, which can be determined by turning the equipment off and on.

ALL OTHER CONDITIONS

In the event that the Gemini 810 + 980 diode laser fails to operate correctly and your distributor representative is unable to help, the system will need to be returned to the manufacturer for repair. There are no user-repairable parts available for the device. It is recommended that the system be returned in its original shipping box. If not available, one can be requested at the time you discuss your service incident with your distributor representative.

TROUBLESHOOTING GUIDE

WHY IS THE AIMING LIGHT OFF OR BARELY VISIBLE?

CAUSE:

- 1 - The laser is in STANDBY mode.
- 2 - The disposable tip is defective.
- 3 - The fiber optic cable is damaged or broken.

SOLUTION:

- 1 - Touch the ACTIVE/STANDBY selection on the keypad to put the system in Active mode.
- 2 - Replace disposable tip with a new tip.
- 3 - The system needs to be sent back to the manufacturer for repair. Contact your distributor representative for return instructions.

WHY DOES THE LASER STOP FIRING MID-PROCEDURE OR FAIL TO TURN ON?

CAUSE:

- 1 - The laser diode is too hot and needs time to cool down before continued use.
- 2 - Output levels are more than $\pm 20\%$ of the set value.
- 3 - Battery charge is too low to operate the laser.

SOLUTION:

- 1 - Allow 10-15 minutes for laser to cool down.
- 2 - Turn off the laser unit and wait 5 minutes, then turn the unit back on. If the laser performs when re-tried, the microprocessor has been able to make adjustments and the unit will function properly. If the unit fails to fire when re-tried, the device will need to be sent for re-calibration by the manufacturer.
- 3 - Plug in the power adapter and let the laser unit charge for 60 minutes. You can continue using the laser immediately after plugging in the external power.

I LOST CONNECTION WITH THE ACTIVATION PEDAL

CAUSE:

- 1 - Wireless interference with activation pedal.
- 2 - Activation pedal is out of range.

SOLUTION:

- 1 - Re-sync the footpedal by turning the laser unit off, waiting 10 seconds, and turning it back on. Step on the activation pedal after a wavelength mode is selected to re-sync.
- 2 - Bring activation pedal closer to laser unit.

SERVICE AND TROUBLESHOOTING

WHY DOES THE LASER NOT FIRE WHEN I PRESS THE ACTIVATION PEDAL?

- CAUSE:
- 1 - Activation pedal not connected.
 - 2 - Activation pedal AA Batteries are too low to operate.
 - 3 - Laser is in Standby mode.

- SOLUTION:
- 1 - Check to see if the Bluetooth indicator on the activation pedal is on, and if there is a Bluetooth indicator on the top right of the display. If either indicator is off, re-sync the footpedal by turning the laser unit off, waiting 10 seconds, and turning it back on. Step on the activation pedal after a wavelength mode is selected to re-sync.
 - 2 - Replace the two AA batteries in the activation pedal.
 - 3 - Touch the ACTIVE/STANDBY selection to activate the laser .

I CAN HEAR THE LASER FIRING BUT IT IS CUTTING SLOWLY OR NOT CUTTING AT ALL

- CAUSE:
- 1 - Fiber tip is not initiated.
 - 2 - Fiber tip is not in contact with tissue.
 - 3 - Power setting is too low.

- SOLUTION:
- 1 - The fiber tip should be initiated for any procedures where removal of tissue is necessary.
 - 2 - The fiber tip should be in contact with target tissues where removal of tissue is necessary.
 - 3 - The laser unit should be set at the proper power setting for the procedure. The preset procedures are a good reference point.

SERVICE AND TROUBLESHOOTING

ERROR MESSAGES

An error message will flash where the Power Indicator is normally displayed.

OUTPUT POWER VARIANCE

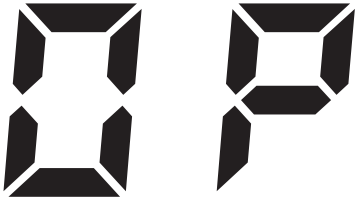

If you notice an Error code “OP” flashing on the display, it means the laser output power is beyond the 20% ± variance per regulation.

Please restart the laser unit by pressing the ON/OFF button. If problem persists, contact the manufacturer for assistance.

OVERHEATING

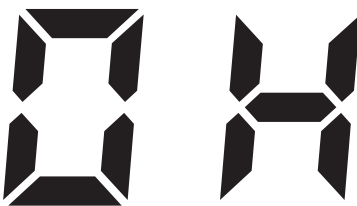

The Gemini 810 + 980 diode laser is designed to perform surgical procedures at a specific temperature. High power and long procedures may cause the laser unit to heat up to the temperature threshold.

Please wait a few minutes for the temperature to decrease before resuming normal operations.

ACTIVATION PEDAL DISCONNECTED



The Gemini 810 + 980 diode laser is equipped with a long range Bluetooth chip.

Please check the two AA batteries in the activation pedal and replace if needed. Press the activation pedal once to reactivate the connection with the laser unit. The Bluetooth icon on the activation pedal will turn blue, and the Bluetooth symbol will appear on the display, when the laser is in Active mode and the activation pedal is successfully connected.

DISPLAY FAILURE



“SOUND”

If the glass electroluminescent display fails to turn on, there will be an audio warning that says, “Display communication error.”

Please plug the AC/DC power supply into the laser unit and restart the system by pressing the ON/OFF button. If the problem persists, contact the manufacturer for assistance.

REGULATORY COMPLIANCE

FCC/INDUSTRY CANADA TWO PART STATEMENT

This device complies with FCC Part 15 and Industry Canada license exempt RSS standard(s). Operation is subject to the following two conditions: (1) this device may not cause interference, and (2) this device must accept any interference, including interference that may cause undesired operation of the device.

Le présent appareil est conforme aux CNR d'Industrie Canada applicables aux appareils radio exempts de licence. L'exploitation est autorisée aux deux conditions suivantes: (1) l'appareil ne doit pas produire de brouillage, et (2) l'utilisateur de l'appareil doit accepter tout brouillage radioélectrique subi, même si le brouillage est susceptible d'en compromettre le fonctionnement.

PER INDUSTRY CANADA RSS RULES:

This device complies with Health Canada's Safety Code. The installer of this device should ensure that RF radiation is not emitted in excess of Health Canada's requirement.

Information can be obtained at http://www.hc-sc.gc.ca/ewh-semt/pubs/radiation/radio_guide-lignes_direct/index-eng.php

Cet appareil est conforme avec Santé Canada Code de sécurité 6. Le programme d'installation de cet appareil doit s'assurer que les rayonnements RF n'est pas émis au-delà de l'exigence de Santé Canada.

Les informations peuvent être obtenues: http://www.hc-sc.gc.ca/ewh-semt/pubs/radiation/radio_guide-lignes_direct/index-eng.php

ELECTROMAGNETIC ENVIRONMENT GUIDANCE

ELECTROMAGNETIC COMPATIBILITY

Notice: The Gemini 810 + 980 diode laser complies with all requirements for electromagnetic compatibility according to IEC 60601-1-2: 2014.

CAUTION

Medical electrical equipment needs special precautions regarding electromagnetic compatibility (EMC) and needs to be installed and put into service according to the EMC information provided in the following tables.

Portable and mobile Radio Frequency (RF) communications equipment can affect medical electrical equipment.

WARNING

The use of accessories other than those specified, except those supplied or sold by Ultradent Products, Inc., as replacement parts for internal or external components, may result in increased EMISSIONS or decreased IMMUNITY of the Gemini 810 + 980 diode laser.

Accessories: Medical grade power supply - Maximum length 6ft (1.8 meters)
Ultradent P/N: 8981

Activation Pedal: Wireless Bluetooth at 2.4GHz
Ultradent P/N: 8982 or 8992

Description: The Activation Pedal uses Bluetooth BLE 4.0 technology, which operates at a frequency of 2402 to 2480 MHz with TX power of +0dBm and RX sensitivity of -93dBm and uses GFSK modulation. The pedal is pre-configured by the manufacturer to only sync with the Gemini laser unit that has a matching unique identifier. This prevents interference with other RF wireless technologies that may be present.

As a safety measure, any termination of the Bluetooth link between the activation pedal and the laser unit during use will result in the immediate termination of any laser emission. Reference the Service and Troubleshooting section of this manual should you encounter any connectivity issues between the laser unit and the activation pedal.

This device has passed wireless coexistence testing with common devices found in dental practices at a minimum separation distance of 30 cm.

ELECTROMAGNETIC ENVIRONMENT GUIDANCE

DEFINITIONS

Emission (electromagnetic): When electromagnetic energy is emitted by a source.

Interference Immunity: The ability of a device or system to work without errors even if there is electromagnetic interference.

Immunity Level: The maximum level of a certain electromagnetic interference that affects a particular device or system, where the device or system remains operative with a certain level of performance.

ELECTROMAGNETIC EMISSION

The Gemini 810 + 980 diode laser is intended for operation in the electromagnetic environment specified below. The customer or user of the Gemini laser should make sure that it is used in such an environment.

EMISSION TEST	COMPLIANCE	ELECTROMAGNETIC ENVIRONMENT – GUIDANCE
RF emissions according to CISPR 11	GROUP 1	The Gemini laser is suitable for use in all establishments, including domestic establishments and those directly connected to the public low-voltage power supply network that supplies buildings used for domestic purposes.
RF emissions according to CISPR 11	CLASS B	
Harmonic emissions according to IEC 61000-3-2	CLASS A	
Voltage fluctuations/flicker emissions according to IEC 61000-3-3	COMPLIES	

ELECTROMAGNETIC ENVIRONMENT GUIDANCE

INTERFERENCE IMMUNITY

The Gemini 810 + 980 diode laser is intended for operation in the electromagnetic environment specified below. The customer or user of the Gemini laser should make sure that it is used in such an environment.

<u>INTERFERENCE IMMUNITY TEST</u>	<u>IEC 60601-1-2 TEST LEVEL</u>	<u>COMPLIANCE LEVEL</u>	<u>ELECTROMAGNETIC ENVIRONMENT GUIDANCE</u>
Electrostatic discharge (ESD) according to IEC 61000-4-2	± 6 kV contact discharge ± 8 kV air discharge	± 6 kV contact discharge ± 8 kV air discharge	Floors should be wood, concrete, or ceramic tile. If floors are covered with synthetic material, the relative humidity should be at least 30%.
Electrical fast transient/burst according to IEC 61000-4-4	± 1kV for input and output lines ± 2 kV for power supply lines	± 1kV for input and output lines ± 2 kV for power supply lines	The quality of the line power supply should be that of a typical commercial or hospital environment.
Surge voltages according to IEC 61000-4-5	± 1 kV differential mode ± 2 kV common mode voltage	± 1 kV differential mode ± 2 kV common mode voltage	The quality of the line power supply should be that of a typical commercial or hospital environment.
Voltage dips, short interruptions and variations of the power supply according to IEC 61000-4-11	<5 % U_T (>95 % dip in U_T) for 0.5 cycle 40 % U_T (60 % dip in U_T) for 5 cycles 70 % U_T (30 % dip in U_T) for 25 cycles <5 % U_T (>95 % dip in U_T) for 5 s	<5 % U_T (>95 % dip in U_T) for 0.5 cycle 40 % U_T (60 % dip in U_T) for 5 cycles 70 % U_T (30 % dip in U_T) for 25 cycles <5 % U_T (>95 % dip in U_T) for 5 s	The quality of the line power supply should be that of a typical commercial or hospital environment. If the user of the Gemini laser requires it to continue functioning following interruptions of the power supply, it is recommended to have the Gemini laser powered by an uninterruptible power supply or a battery.
Magnetic field of power frequencies (50/60 Hz) according to IEC 61000-4-8	3 A/m	3 A/m	Power frequency magnetic fields should be at levels characteristic of a typical location in a typical commercial or hospital environment

ELECTROMAGNETIC ENVIRONMENT GUIDANCE

IMMUNITY TEST	IEC 60601 TEST LEVEL	COMPLIANCE LEVEL	ELECTROMAGNETIC ENVIRONMENT GUIDANCE
<p>Conducted RF IEC 61000-4-6</p> <p>Radiated RF IEC 61000-4-3</p>	<p>3 Vrms 150 kHz to 80 MHz</p> <p>3 V/m 80 MHz to 2.5 GHz</p>	<p>3 Vrms</p> <p>3 V/m</p>	<p>Portable and mobile radio equipment must not be used within the recommended working clearance from the Gemini laser unit and its cables, which is calculated based on the equation suitable for the relevant transmission frequency.</p> <p>Recommended separation distance</p> <p>$d = [1.2] \sqrt{P}$</p> <p>$d = [1.2] \sqrt{P}$ at 80 MHz to 800 MHz</p> <p>$d = [2.3] \sqrt{P}$ at 800 MHz to 2.5 GHz</p> <p>where P is the nominal transmitter output in watts (W) specified by the transmitter manufacturer and d is the recommended working clearance in meters (m).</p> <p>Field strengths from fixed RF transmitters, as determined by an electromagnetic site survey² should be less than the compliance level³ in each frequency range.</p> <p>Interference is possible in the vicinity of equipment bearing the following graphic symbol.</p> 

NOTES

¹The higher frequency range applies at 80 MHz and 800 MHz.

² Field strengths from fixed transmitters, such as base stations for radio (cellular/cordless) telephones and land mobile radios, amateur radio, AM and FM radio broadcast and TV broadcast, cannot be predicted theoretically with accuracy. An investigation of the location is recommended to determine the electromagnetic environment resulting from stationary HF transmitters. If the measured field strength in the location in which the Gemini 810 + 980 diode laser is used exceeds the applicable RF compliance level above, the Gemini laser unit should be observed to verify normal operation. If unusual performance characteristics are observed, it may be necessary to take additional measures such as reorientation or repositioning of the Gemini 810 + 980 diode laser.

³ Over the frequency range 150kHz to 80MHz, field strengths should be less than 3V/m.

ELECTROMAGNETIC ENVIRONMENT GUIDANCE

WORKING CLEARANCES

The Gemini 810 + 980 diode laser is intended for operation in an electromagnetic environment where radiated HF interference is checked. The customer or the user of the Gemini laser can help prevent electromagnetic interference by duly observing the minimum distances between portable and/or mobile RF communication devices (transmitters) and the Gemini laser unit. These values may vary according to the output power of the relevant communication device as specified below.

RATED MAXIMUM OUTPUT POWER OF TRANSMITTER [W]	WORKING CLEARANCE ACCORDING TO TRANSMISSION FREQUENCY [M]		
	150 KHZ TO 80 MHZ	80 MHZ TO 800 MHZ	800 MHZ TO 2.5 GHZ
	$d = [1.2] \sqrt{P}$	$d = [1.2] \sqrt{P}$	$d = [2.3] \sqrt{P}$
0.01	0.12	0.12	0.23
0.1	0.38	0.38	0.73
1	1.2	1.2	2.3
10	3.8	3.8	7.3
100	12	12	23

For transmitters whose maximum nominal output is not specified in the above table, the recommended working clearance d in meters (m) can be determined using the equation in the corresponding column, where P is the maximum nominal output of the transmitter in watts (W) specified by the transmitter manufacturer.

Remark 1: The higher frequency range applies at 80 MHz and 800 MHz.

Remark 2: These guidelines may not be applicable in all cases. The propagation of electromagnetic waves is influenced by their absorption and reflection by buildings, objects and persons.

LABELING

LASER UNIT

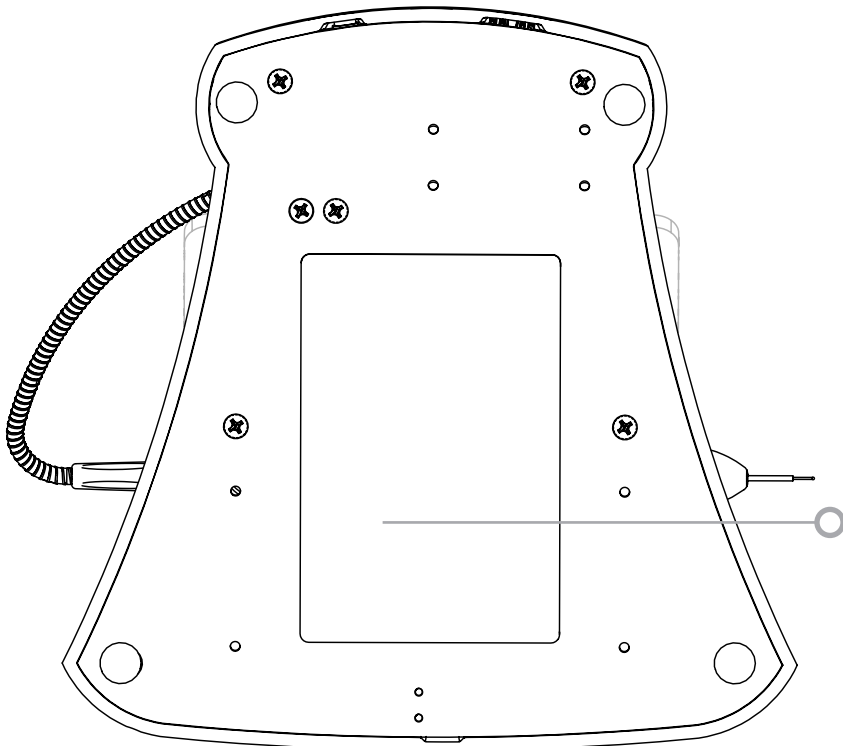

 AZENA MEDICAL, LLC 21 Massolo Dr. - Unit C Pleasant Hill, CA 94523 - USA 1 (800)466-5273		 0086
 ULTRADENT PRODUCTS, INC 505 West 10200 South South Jordan, UT 84095 - USA 1 (888) 230-1420	 EMERGO EUROPE Molenstraat 15 2513 BH, The Hague The Netherlands	 European Rep
 Manufacture Date	 Part Number	 BARCODE LABEL
 Serial Number		
<p>COMPLIES WITH: IEC 60601-2-22:2007 / IEC 60825-1:2007 AS WELL AS TO US FEDERAL REGULATIONS FOR LASER PERFORMANCE STANDARDS SET OUT IN 21CFR 1040.10 AND 1040.11 EXCEPT FOR DEVIATIONS PURSUANT TO LASER NOTICE 50 DATED JUNE 24, 2007</p>		
<p>THIS PRODUCT COMPLIES WITH FDA PERFORMANCE STANDARDS FOR LASER PRODUCTS EXCEPT FOR DEVIATIONS PURSUANT TO LASER NOTICE 50 DATE JUNE 24, 2007</p>		<p>Power Input: 13V - 3.5A Model: GEMINI 810+980 DIODE LASER Connect only to provided power supply.</p>
 DANGER, Visible and/or invisible laser radiation	 The applied part is not conductive to the patient	 Refer to User's Manual
 Non-ionizing Radiation		 ID: Q0Q-BLE113 IC: 5123A-BGTBLE113

ACTIVATION PEDAL

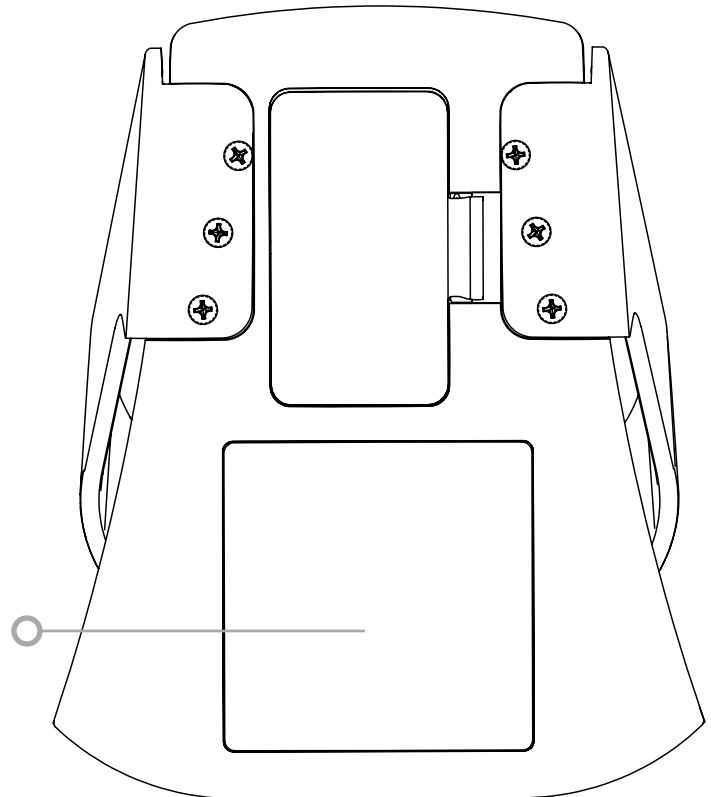

 AZENA MEDICAL, LLC 21 Massolo Dr. - Unit C Pleasant Hill, CA 94523 - USA 1 (800)466-5273	 ULTRADENT PRODUCTS, INC 505 West 10200 South South Jordan, UT 84095 - USA 1 (888) 230-1420	 EMERGO EUROPE Molenstraat 15 2513 BH, The Hague The Netherlands
 Manufacture Date	 Part Number	 BARCODE LABEL
 Serial Number		
<p>Power Input: AA Batteries</p>		<p>Model: GEMINI 810+980 DIODE LASER</p>
<p>COMPLIES WITH: IEC 60601-2-22:2007 / IEC 60825-1:2007 AS WELL AS TO US FEDERAL REGULATIONS FOR LASER PERFORMANCE STANDARDS SET OUT IN 21CFR 1040.10 AND 1040.11 EXCEPT FOR DEVIATIONS PURSUANT TO LASER NOTICE 50 DATED JUNE 24, 2007</p>		
<p>THIS DEVICE COMPLIES WITH PART 15 OF FCC RULES. OPERATION IS SUBJECT TO THE FOLLOWING TWO CONDITIONS:</p> <p>1) THIS DEVICE MAY NOT CAUSE HARMFUL INTERFERENCE</p> <p>2) THIS DEVICE MUST ACCEPT ANY INTERFERENCE RECEIVED INCLUDING INTERFERENCE THAT MAY CAUSE UNDESIRABLE INTERFERENCE</p>		<p> 0086</p> <p>ID: Q0Q-BLE113 IC: 5123A-BGTBLE113</p> <p></p>
 Refer to User's Manual	 Non-ionizing Radiation	

HANDPIECE

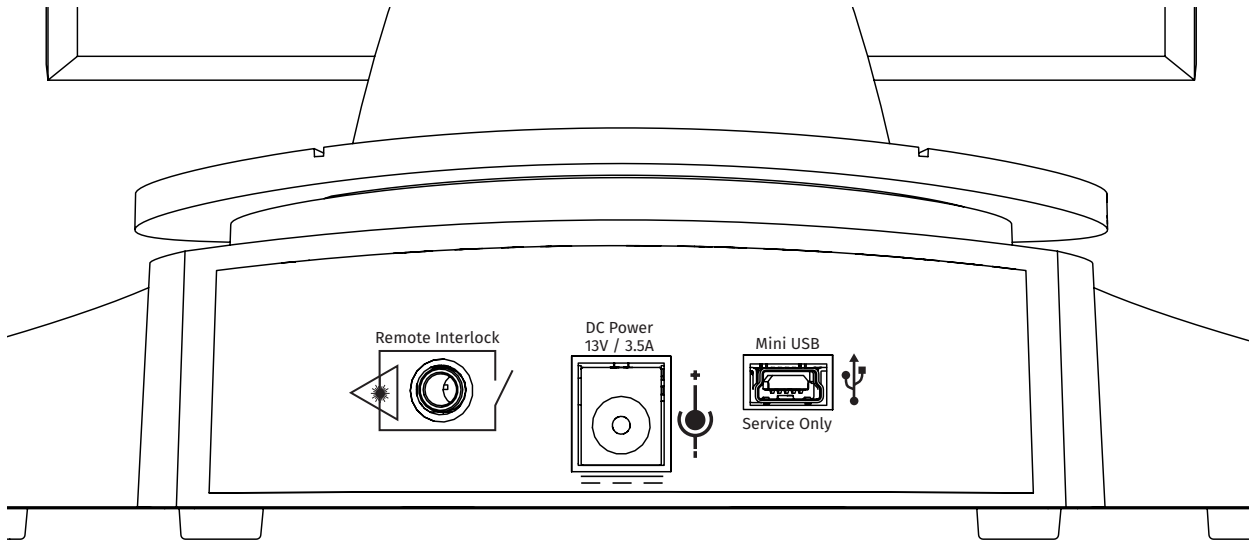
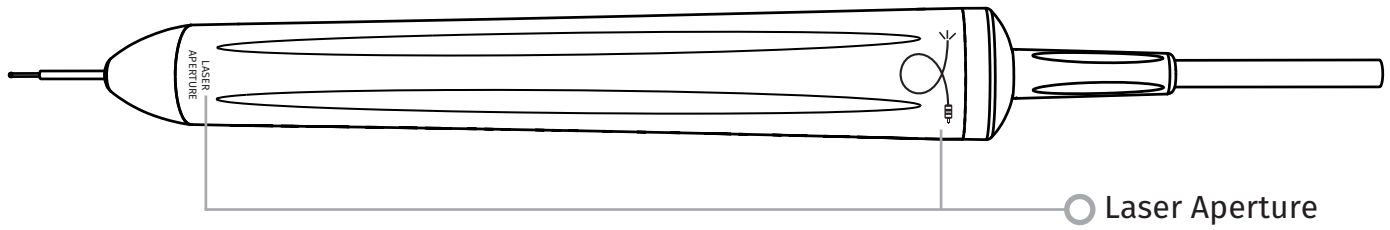







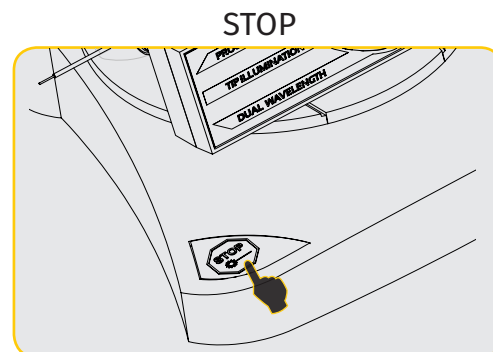
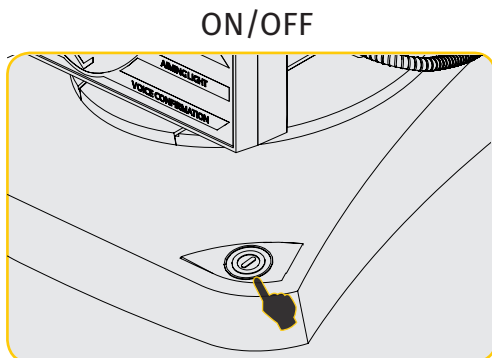





EMERGENCY TERMINATION OF LASER EMISSIONS

The Gemini 810 + 980 diode laser has been designed with several methods to terminate emission of laser energy in emergency situations.

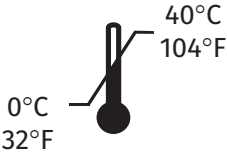
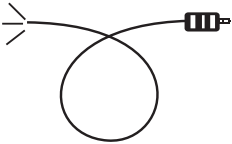
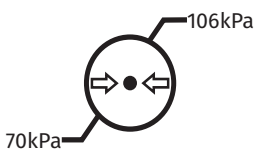
These methods include a power button (ON/OFF) and the emergency (STOP) button located at the front of the laser unit.



LABELING

SYMBOLS	DESCRIPTION	SYMBOLS	
	<p><u>MANUFACTURER</u></p> <p>INDICATES WHICH COMPANY MANUFACTURES</p>		<p><u>SHIP VERTICAL, WITH ARROWS POINTED UPWARD</u></p>
	<p><u>DATE OF MANUFACTURE</u></p> <p>INDICATES THE DATE AND YEAR OF MANUFACTURE</p>		<p><u>FRAGILE - HANDLE WITH CARE</u></p>
	<p><u>CATALOG PART NUMBER</u></p> <p>INDICATES THE MANUFACTURER PART NUMBER.</p>		<p><u>DO NOT USE IF PACKAGE IS DAMAGED</u></p>
	<p><u>SERIAL NUMBER</u></p> <p>INDICATES SERIAL NUMBER FOR THE PRODUCT PART</p>		<p><u>RECOMMENDED STORAGE TEMPERATURE</u></p>
	<p><u>LASER APERTURE</u></p> <p>INDICATES WHERE LASER ENERGY COMES OUT</p>		<p><u>ATMOSPHERIC PRESSURE LIMITATION</u></p>
	<p><u>LASER WARNING</u></p> <p>INDICATES THE SYSTEM CONTAINS A LASER</p>		<p><u>RELATIVE HUMIDITY RANGE</u></p>
	<p><u>WARNING</u></p> <p>INDICATES POSSIBLE EXPOSURE TO BOTH RED AND INFRARED LASER RADIATION</p>		<p><u>KEEP AWAY FROM HEAT/ SUNLIGHT</u></p>
	<p><u>PRESCRIPTION STATEMENT</u></p> <p>FEDERAL LAW RESTRICTS THIS DEVICE TO SALE BY OR ON THE ORDER OF A DENTIST OR PHYSICIAN OR OTHER LICENSED MEDICAL PRACTITIONER</p>		<p><u>KEEP DRY</u></p>

UNIT LABEL

 AZENA MEDICAL, LLC 21 Massolo Dr. - Unit C Pleasant Hill, CA 94523 - USA 1 (800)466-5273		 0086
 ULTRADENT PRODUCTS, INC 505 West 10200 South South Jordan, UT 84095 - USA 1 (888) 230-1420	 EMERGO EUROPE Molenstraat 15 2513 BH, The Hague The Netherlands	 European Rep
 Manufacture Date		
 Part Number		
 Serial Number		
<p>COMPLIES WITH: IEC 60601-2-22:2007 / IEC 60825-1:2007 AS WELL AS TO US FEDERAL REGULATIONS FOR LASER PERFORMANCE STANDARDS SET OUT IN 21CFR 1040.10 AND 1040.11 EXCEPT FOR DEVIATIONS PURSUANT TO LASER NOTICE 50 DATED JUNE 24, 2007</p>		
<p>THIS PRODUCT COMPLIES WITH FDA PERFORMANCE STANDARDS FOR LASER PRODUCTS EXCEPT FOR DEVIATIONS PURSUANT TO LASER NOTICE 50 DATE JUNE 24, 2007</p>		<p>Power Input: 13V - 3.5A Model: GEMINI 810+980 DIODE LASER Connect only to provided power supply.</p>
		 ID: Q0Q-BLE113 IC: 5123A-BGTBLE113

PEDAL LABEL

 AZENA MEDICAL, LLC 21 Massolo Dr. - Unit C Pleasant Hill, CA 94523 - USA 1 (800)466-5273	 ULTRADENT PRODUCTS, INC 505 West 10200 South South Jordan, UT 84095 - USA 1 (888) 230-1420	 EMERGO EUROPE Molenstraat 15 2513 BH, The Hague The Netherlands
 Manufacture Date		
 Part Number		
 Serial Number		
<p>Power Input: AA Batteries Model: GEMINI 810+980 DIODE LASER</p>		
<p>COMPLIES WITH: IEC 60601-2-22:2007 / IEC 60825-1:2007 AS WELL AS TO US FEDERAL REGULATIONS FOR LASER PERFORMANCE STANDARDS SET OUT IN 21CFR 1040.10 AND 1040.11 EXCEPT FOR DEVIATIONS PURSUANT TO LASER NOTICE 50 DATED JUNE 24, 2007</p>		
<p>THIS DEVICE COMPLIES WITH PART 15 OF FCC RULES. OPERATION IS SUBJECT TO THE FOLLOWING TWO CONDITIONS:</p>		<p>1) THIS DEVICE MAY NOT CAUSE HARMFUL INTERFERENCE</p> <p>2) THIS DEVICE MUST ACCEPT ANY INTERFERENCE RECEIVED INCLUDING INTERFERENCE THAT MAY CAUSE UNDESIRABLE INTERFERENCE</p>
		 ID: Q0Q-BLE113 IC: 5123A-BGTBLE113

SYMBOLS



DESCRIPTION

TYPE B APPLIED PART

THE APPLIED PART IS NOT CONDUCTIVE TO THE PATIENT

REFER TO USER'S MANUAL

LASER STOP

EMERGENCY SWITCH TO STOP LASER OUTPUT POWER

NON-IONIZING RADIATION

WESTERN EUROPE ELECTRONIC AND ELECTRICAL DISPOSAL STANDARD (WEEE)

GEMINI™ 2 YEAR WARRANTY

810 + 980 DIODE LASER

Seller warrants the Products to be free from defects in materials and workmanship for a period of two years from the date of shipment, except for consumables. If within such period any Products shall be proved to Seller's satisfaction to be defective, it shall be (i) repaired using new or refurbished parts, or (ii) replaced with a new or refurbished product, at Seller's sole discretion. Such repair or replacement shall be Seller's sole obligation and Buyer's exclusive remedy under this Warranty and shall be conditioned, at Seller's option, upon return of such Products to Seller, f.o.b. its factory. This Warranty only covers Product issues caused by defects in material or workmanship during ordinary consumer use; it does not cover Product issues caused by any other reason, including but not limited to acts of God, modifications of or to any part of the Product, improper testing, assembly, mishandling, misuse, neglect, adjustments, alterations to the products, improper operation contrary to current instructions relating to installation, maintenance or operation, or contrary to industry standards relating to acceptable input power.

THIS WARRANTY IS EXCLUSIVE AND IN LIEU OF ALL OTHER REPRESENTATIONS AND WARRANTIES, EXPRESS OR IMPLIED; AND SELLER EXPRESSLY DISCLAIMS AND EXCLUDES ANY IMPLIED WARRANTY OF MERCHANTABILITY OR FITNESS FOR ANY PARTICULAR PURPOSE. SELLER SHALL HAVE NO OBLIGATION OR LIABILITY TO REFUND ANY PORTION OF THE PURCHASE PRICE AND SHALL NOT BE LIABLE FOR ANY SPECIAL, EXEMPLARY, INCIDENTAL, CONSEQUENTIAL OR PUNITIVE DAMAGES OR LOST PROFITS, OR DAMAGE TO PERSONS OR INJURY IN CONNECTION WITH THE PURCHASE OR USE OF THE INSTRUMENT

800.552.5512 ULTRADENT.COM



Manufactured by Azena Medical, 21 Massolo Dr, Pleasant Hill, CA 94523, Made in USA.
Distributed by Ultradent Products, Inc., 505 West Ultradent Drive, South Jordan, Utah 84095

8989.2 112216

ULTRADENT
PRODUCTS, INC.





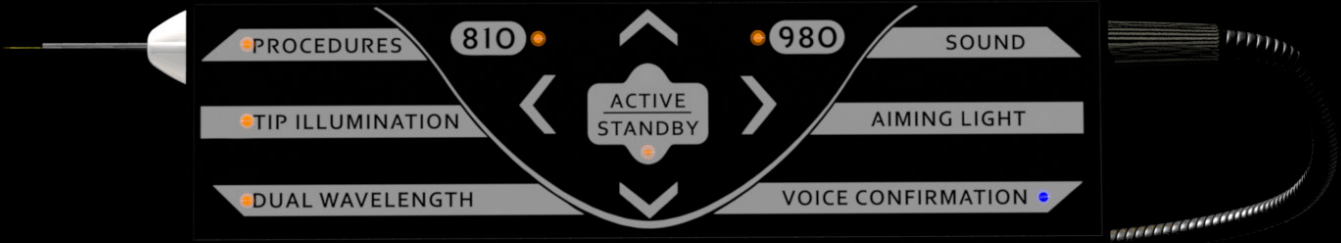

GEMINI™

810 + 980 DIODE LASER

800.552.5512 ULTRADENT.COM



Manufactured by Azena Medical, 21 Massolo Dr, Pleasant Hill, CA 94523. Made in USA.
Distributed by Ultradent Products, Inc. 505 West Ultradent Drive, South Jordan, Utah 84095

8989.2 112216

ULTRADENT
PRODUCTS, INC.